



Sample Preparation and Laboratory Automation

Contents

Goals of Sample Preparation	5	PoraPak Rxn Cartridges for Post-Synthesis Cleanup	34
Benefits of Solid-Phase Extraction	5	Vacuum Manifold and Accessories	35
Selecting the Correct SPE Format	6	Vacuum Manifold for Use with SPE Cartridges	35
Oasis Solid-Phase Extraction (SPE) Products	8	Sep-Pak Cartridge Connections Kit	36
A Breakthrough in SPE	9	Sep-Pak Cartridge Accessories	36
Oasis PRiME HLB	12	DisQuE Sample Preparation Solutions for QuEChERS	37
Oasis PRiME MCX	13	DisQuE Kitted Solutions	37
Oasis MCX for Basic Compounds	14	DisQuE Extraction and Cleanup Tubes and Pouches	38
Oasis MAX for Acidic Compounds	15	Waters/Pall Life Sciences Sample and Solvent Filtration Products	39
Oasis WCX for Strong Basic Compounds	15	Filter Design and Membrane Choices	40
Oasis WAX for Strong Acidic Compounds	16	Solvent Filtration Apparatus	43
Oasis Sorbent Selection Tools for Convenient Method Development	16	Liquid Handling Automations	44
XBridge OSM Cartridges	18	Andrew+ Pipetting Robot	44
SPE Columns for Waters UPLC with On-Line SPE Technology	18	Pipette+ System	46
Oasis Glass Cartridges for PPT Detection Levels	18	OneLab+ Software	48
Ostro Pass-Through Sample Preparation Product	19	Sample Processing Devices and Accessories	49
Sep-Pak Solid-Phase Extraction (SPE) Products	20	Otto SPEcialist	49
Anatomy of Sep-Pak Cartridges	26		
General Extraction Protocols for Sep-Pak Cartridges	27		
Certified Sep-Pak Solid-Phase Extraction (SPE) Cartridges	31		
Certified Sep-Pak Sorbent Selection Guide	32		

Sample Preparation

Goals of Sample Preparation

Successful sample preparation for most analytical techniques (HPLC, UPLC,[™] LC-MS, UV, GC, etc.) has three primary objectives. It needs to provide the sample component of interest:

- In solution
- Free from interfering matrix elements
- At a concentration appropriate for detection or measurement

Waters[™] Sample Preparation Solutions make it easy to produce samples that are free of matrix interferences, leading to more robust and predictable analytical results. Based on simple, logical workflows that produce cleaner samples through targeted separations, Waters Sample Preparation Products maximize sensitivity, increase throughput, and enable the development of robust methods.

Benefits of Solid-Phase Extraction

Solid-phase extraction (SPE) is a sample preparation technology that uses solid particle, chromatographic packing material contained in a device to chemically separate the different components of a sample. It is used across many different industries and application areas to ensure that the sample of interest is in an appropriate state of cleanliness and concentration to achieve successful analytical results for a variety of analytical measurement techniques.

While there are many reasons for using SPE, there are several major benefits that SPE provides:

- Simplification of complex sample matrix - SPE separates the compound of interest from matrix interferences that make accurate and reproducible analysis difficult to obtain
- Reduce ion suppression or enhancement in MS applications - SPE provides cleaner sample extracts resulting in improved MS-signal response and overall method robustness
- Trace enrichment of very low level compounds - SPE provides the ability to concentrate specific compounds of interest in a sample to improve method sensitivity and detection limits
- Ability to fractionate compounds by class from a sample matrix - SPE can target and isolate specific classes of compounds depending on the needs of the analysis
- Improve robustness of analytical methods - SPE provides a cleaner sample extract that translates directly to more robust and reproducible analytical results
- Increase column lifetime - SPE removes matrix interferences which can accumulate on chromatographic columns and cause poor lifetime and premature column failure

Selecting the Correct SPE Format

Formats		
μElution Plates	<ul style="list-style-type: none"> Patented μElution™ plate design. Ideal for SPE cleanup and analyte enrichment of sample volumes ranging from 10 μL to 375 μL. No evaporation and reconstitution necessary due to elution volumes as low as 25 μL. Up to a 15x increase in concentration. Compatible with most liquid-handling robotic systems for automated, reliable, high-throughput SPE (HT-SPE). 	
96-well Extraction Plates	<ul style="list-style-type: none"> Innovative, award-winning, two-stage well design. High throughput and high recovery. Available with 5 mg, 10 mg, 30 mg, and 60 mg of sorbent per well. Compatible with most liquid-handling robotic systems for automated, reliable, high throughput SPE (HT-SPE). 	
Syringe-barrel Cartridges	<ul style="list-style-type: none"> Ultra-clean syringe barrel and frits. Available with cartridge sizes ranging from 1 cc/10 mg up to 35 cc/6 g. Flangeless syringe-barrel cartridges available in 1 cc, 3 cc, and 6 cc configurations. 	
Luer-tip Plus Cartridge (Format)	<ul style="list-style-type: none"> Plus-style cartridge with Luer inlet hub easily attaches to a syringe. Allows for easy SPE without the need for a vacuum manifold. Available in many sorbent types and specialty chemistries. 	
Glass Cartridges	<ul style="list-style-type: none"> Ultra-clean glass syringe with Teflon frit. For trace level detection and analysis at part-per-trillion levels. Available in 5 cc with 200 mg of sorbent configuration. 	
On-line Columns and Cartridges	<ul style="list-style-type: none"> For rugged, reproducible, and ultra-fast online analysis. Wide choice of configurations, particle sizes, and sorbent chemistries. Available with six, patented, Oasis™ Sorbents—HLB, PRiME HLB, MCX, MAX, WCX, and WAX. High recovery and reproducible results for a wide range of compounds. Cartridge format for use with Spark Holland Prospekt-2/Symbiosis systems also available. 	

Sorbent Amount and Solvent Selection for the Generic SPE Method

The suggested amount of sorbent in a cartridge or a plate required for your application is given in the table to the right. Due to the increased capacity of the Oasis sorbents, you can use less sorbent than you would normally need if you used a silica-based packing. When converting from C₁₈ silica-based sorbents to Oasis SPE Sorbents, use approximately two-thirds less Oasis sorbent (100 mg C₁₈ sorbent = 30 mg Oasis sorbent).

DID YOU KNOW...

Sample Pretreatment Suggestion

Applying one or more of the following steps before loading your sample may improve your results:

1. Dilute sample 1:1 with buffer to improve flow during loading
2. Dilute 1:1 or greater with 4% phosphoric acid or other acids
3. Filter through 0.45 µm membrane
4. Centrifuge @ ≥3000 rpm

Capacity and Elution Volume of Oasis 96-well Plates and Cartridges

Sorbent Per Device	Maximum Mass Capacity	Typical Sample Volumes	Elution Volume
2 mg (µElution Plate)*	60–400 µg	10–375 µL	25 µL**
5 mg*	0.15–1 mg	10–100 µL	≤150 µL
10 mg	0.35–2 mg	50–200 µL	≤250 µL
30 mg	1–5 mg	100 µL–1 mL	≥400 µL
60 mg	2–10 mg	200 µL–2 mL	≥800 µL

* Available only in 96-well plate formats.

**µElution Plate requires no evaporation step.

Tips for Selecting Elution Solvents for the Generic SPE Method (1-D)* *The elution solvent is selected based on polarity of analyte.*

Solvent	Solvent Type	Relative Elution Strength**	Comments
Methanol	Proton donor	1.0	Disrupts H-bonding
Acetonitrile	Dipole-dipole	3.1	Medium polarity drugs
Tetrahydrofuran	Dipole-dipole	3.7	Medium polarity drugs
Acetone	Dipole-dipole	8.8	Medium polarity drugs
Ethyl acetate	Dipole-dipole	High	Non-polar drugs and GC compatible
Methylene chloride	Dipole-dipole	High	Non-polar drugs and GC compatible

* When using solvents other than methanol, add 10–30% of proton donor solvent such as methanol to disrupt H-bonding on the Oasis HLB sorbent.

**High-Purity Solvent Guide, Burdick and Jackson Laboratories, Inc. Solvent Properties of Common Liquids, L.R. Snyder, J. Chromatogr., 92, 223 (1974); J. Chromatogr. Sci. 16, 223 (1978).

Need more help getting started with solid phase extraction?

[Download our Oasis Reference Cards](#)

[Download our Oasis Peptide Bioanalysis Reference Cards](#)



APPLICATION AREA: Sample Preparation for Analysis of THC and Metabolites in Whole Blood from Impaired Drivers

"After evaluating many of the SPE products currently on the market on the criteria of recovery, matrix cleanup, ease of use, and cost, Oasis PRiME HLB µElution plate by far is the best option for the analysis of drugs of abuse in whole blood samples. Waters provided excellent support through application notes, in-person training and method development, troubleshooting, and equipment support throughout the optimization and validation process. The µElution plates demonstrate excellent reproducibility, recovery, and matrix cleanup, even with a complex matrix such as whole blood. The 96-well plate form factor will support a lot of scalability for our lab as we receive additional samples, and the Waters positive pressure manifold makes sample processing extremely easy and rapid. Overall, a great system for tricky analytes and matrices!"

REVIEWER: David Patlak

ORGANIZATION: Vermont Forensic Laboratory



Oasis Solid-Phase Extraction (SPE) Products

Waters introduced Oasis HLB in 1996, effectively changing the way scientists performed SPE. Constructed with a water-wettable copolymer that is stable from pH 0–14, Oasis HLB created a whole new range of solid-phase extraction method development possibilities. It is the gold standard in SPE, trusted by scientists around the world.

The Oasis SPE Family of Sorbents

As a unique, water-wettable polymeric sorbent, Oasis products can be used without the conditioning and equilibration steps required by other polymeric and silica-based sorbents. Historically, those steps were required to obtain retention of analytes by reversed-phase SPE. The water-wettable nature of Oasis sorbents allows direct loading of aqueous samples without sacrificing recovery.

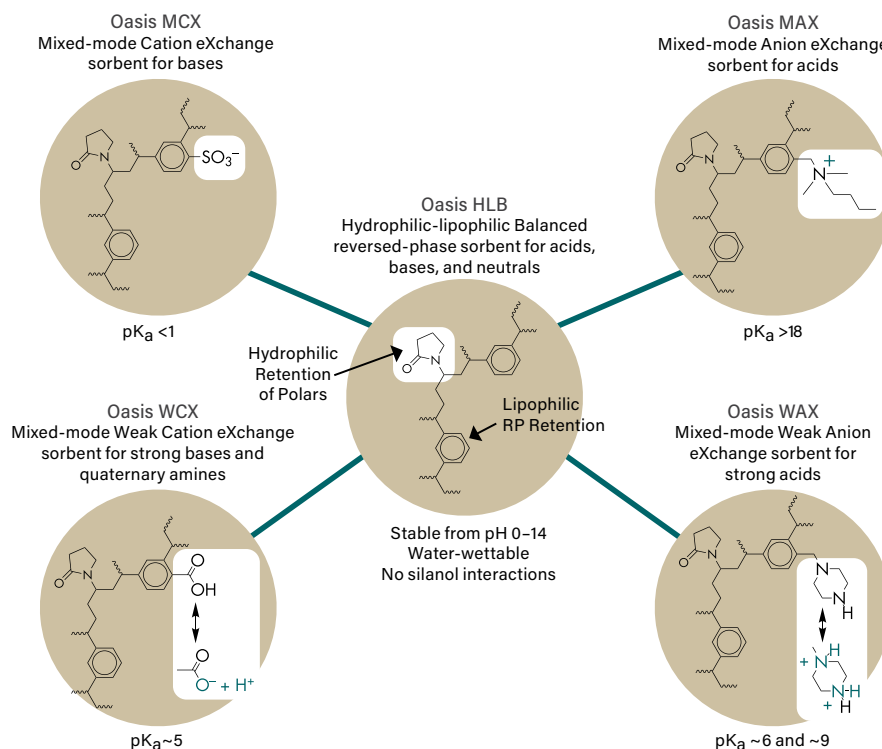

Oasis HLB is the backbone of all Oasis sorbents. It is a multi-purpose, reversed-phase sorbent that provides high capacity for a wide range of compounds.

Oasis PRiME HLB* was designed to make solid-phase extraction easy to implement into routine laboratory use by providing generic, simple methods that remove 95% of common matrix interferences such as phospholipids, fats, salts, and proteins. It produces the cleanest sample eluates with a simple, two- or three-step protocol.

Oasis PRiME MCX* combines the simplicity and cleanliness of Oasis PRiME HLB with the specificity of a cation-exchanger for compounds with basic characteristics, and provides the perfect solution for targeted sample cleanup.

Analyte specificity and sensitivity can be increased by using a **Mixed-Mode Oasis** sorbent, which includes both reversed-phase and ion-exchange functionality for orthogonal sample preparation.

*Oasis PRiME HLB is a proprietary, patent-pending sorbent. Oasis PRiME HLB and MCX have application patents pending.

A BREAKTHROUGH IN SPE

Through the combination of innovative sorbent technology and hardware design, Oasis products have become the first choice in solid-phase extraction (SPE). Oasis products are trusted by separation scientists across the globe to meet a wide variety of sample preparation needs, ranging from a simple and fast matrix cleanup to the need to solve the most difficult and highly selective sample preparation challenges. Researchers rely on the superior technical performance of Oasis products to achieve unmatched purity, consistency, and quality in their sample preparation methods.

What Is the Ideal SPE Method?

- ✓ Easy to implement
- ✓ Reproducible and robust
- ✓ Fast
- ✓ Achieves your goals

[Start Here]

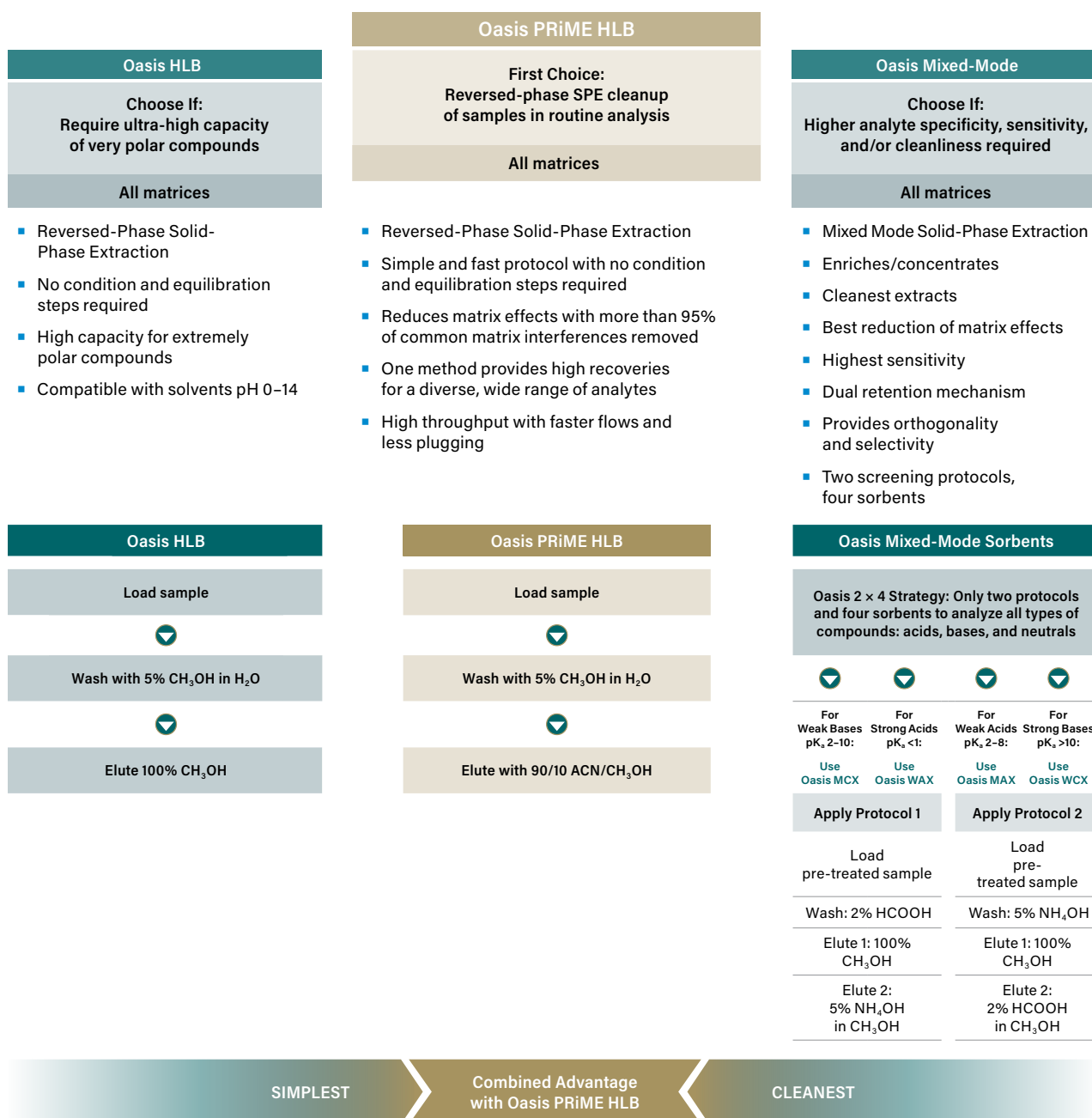

For an additional level of phospholipid clean-up for basic analytes, Oasis PRiME MCX is recommended. See more details on [page 13](#).

Ordering Information

Oasis Product Selection Guide



	1 cc/10 mg	1 cc/10 mg	1 cc/30 mg	1 cc/30 mg	1 cc/30 mg	3 cc/60 mg	3 cc/60 mg	3 cc/60 mg	3 cc/150 mg	3 cc/540 mg	3 cc/540 mg	6 cc/150 mg
	Flangeless			Flangeless	Gilson Adapter		Flangeless	Gilson Adapter		Flangeless		
Sorbent	100/box	100/box	100/box	100/box	500/box	100/box	100/box	500/box	100/box	100/box	100/box	30/box
Oasis PRIME HLB	—	—	186008055	—	—	186008056	—	—	186008717	—	—	—
Oasis PRIME MCX	—	—	186008917	—	—	186008918	—	—	—	—	—	186008919
Oasis HLB 30 µm	186000383	186006339	WAT094225	186001879	WAT058882	WAT094226	186001880	WAT058883	—	—	—	186003365
Oasis HLB 60 µm	—	—	—	—	—	—	—	—	—	186004134	186003852	186003379
Oasis MCX 30 µm	186004648	186006340	186000252	186001881	186001888	186000254	186001882	—	—	—	—	186000256
Oasis MCX 60 µm	—	—	186000782	—	—	186000253	—	—	—	—	—	186000255
Oasis MAX 30 µm	186004649	186006341	186000366	186001883	—	186000367	186001884	—	—	—	—	186000369
Oasis MAX 60 µm	—	—	—	—	—	186000368	—	—	—	—	—	186000370
Oasis WCX 30 µm	186004650	186006342	186002494	186006499	—	186002495	186006501	—	—	—	—	186002498
Oasis WCX 60 µm	—	—	186002496	—	—	186002497	—	—	—	—	—	—
Oasis WAX 30 µm	186004651	186006343	186002489	186006500	—	186002490	186006502	—	—	—	—	186002493
Oasis WAX 60 µm	—	—	186002491	—	—	186002492	—	—	—	—	—	—

Simplifying Solid-Phase Extraction

Traditionally, solid-phase extraction methods have required condition and equilibration steps to prepare the sorbent for sample introduction. The condition step was required to wet the sorbent and allow liquid to enter the pores, enabling retention within the sorbent. Once wetted, the sorbent needed to be equilibrated with aqueous solution to prepare it for aqueous sample loading. Since Oasis HLB is a water-wettable sorbent, the analytes can interact with the sorbent and are retained when loaded directly onto the sorbent in an aqueous sample solution. This eliminates the condition and equilibration steps from the traditional solid-phase extraction protocol and reduces the number of processing steps from 5 to 3. The result is an average reduction in solvent consumption of up to 70% and a 40% savings in sample preparation time.

The ability to simplify and shorten SPE protocols is due to the unique water-wettable, balanced nature of the hydrophilic/lipophilic Oasis sorbent.



	6 cc/200 mg	6 cc/400 mg	6 cc/500 mg	12 cc/500 mg	20 cc/1 g	35 cc/6 g	225 mg	100 mg	30 mg	60 mg	5 cc/200 mg
	Flangeless						Plus Short	Plus Light	Vac RC	Vac RC	Glass Cartridge
Sorbent	30/box	100/box	30/box	20/box	20/box	10/box	50/box	50/box	50/box	50/box	30/box
Oasis PRiME HLB	186008057	—	186008718	—	—	—	186008887¹	186008886	—	—	—
Oasis HLB 30 µm	WAT106202	—	—	—	—	—	—	186005125²	186000382	186000381	—
Oasis HLB 60 µm	—	—	186000115	186000116	186000117	186000118	186000132	—	—	—	186000683
Oasis MCX 30 µm	—	—	—	—	—	—	—	—	—	186000261	—
Oasis MCX 60 µm	—	—	186000776	—	186000777	186000778	186003516	—	—	186000380	—
Oasis MAX 30 µm	—	186001855	—	—	—	—	—	—	186000372	186000371	—
Oasis MAX 60 µm	—	—	186000865	—	—	—	186003517	—	—	186000378	—
Oasis WCX 30 µm	—	—	—	—	—	—	—	—	—	—	—
Oasis WCX 60 µm	—	—	186004646	—	—	—	186003518	—	—	—	—
Oasis WAX 30 µm	—	—	—	—	—	—	—	—	—	—	—
Oasis WAX 60 µm	—	—	186004647	—	—	—	186003519	—	—	—	—

¹335 mg for Oasis PRiME HLB.

²30 mg for Oasis HLB.

Save Time and Solvent by Moving from a 5-Step Protocol to a 3-Step

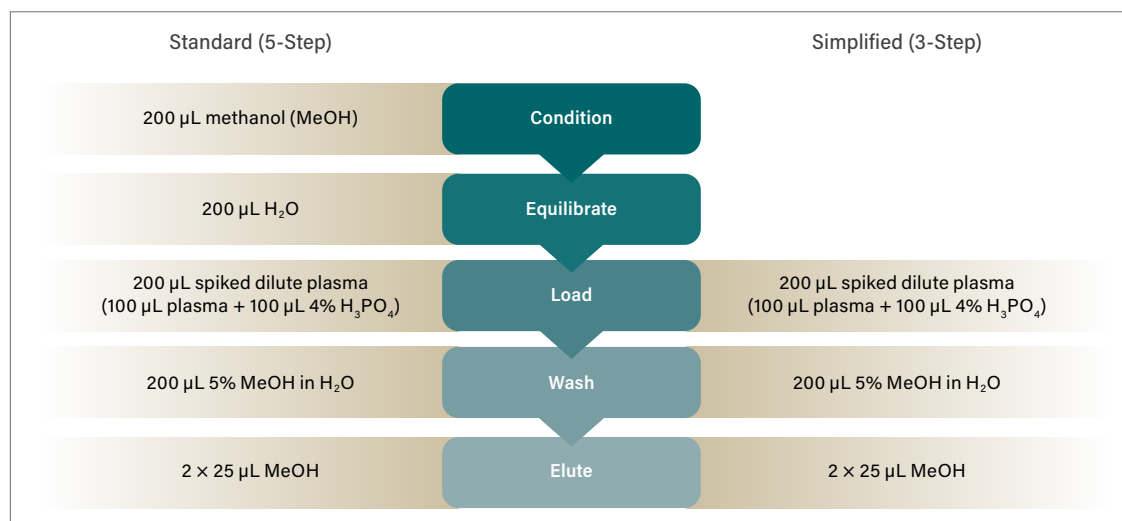

Traditional 5-step SPE protocol vs. the 3-step SPE protocol using an Oasis HLB µElution Plate. (Typical loading range between 10–375 µL undiluted plasma.)

OASIS PRiME HLB

Oasis PRiME HLB is the first-of-its-kind SPE sorbent that sets the new performance standard for routine analyses. The unique, patent-pending Oasis PRiME HLB sorbent provides cleaner samples in less time and with less effort.

- Removes 95% of common matrix interferences such as salts, proteins, and phospholipids
- Ability to concentrate analytes
- Faster, more predictable analysis times
- Directly load pre-treated samples without conditioning and equilibration

Simpler: Easy, efficient protocols

The Oasis PRiME HLB copolymer is extremely water-wettable, making it possible to eliminate the condition and equilibration steps that are absolutely essential when using silica-based or other polymeric sorbents. This saves valuable sample processing time and costly solvent purchase and disposal.

Faster: More even flows across cartridges and plates with less plugging

Oasis PRiME HLB has been designed to increase speed within the device and in your workflow. Flow times through the device are 30–50% faster for urine and plasma. Desired flow rates are achieved using less vacuum or positive pressure than required with other SPE devices.

Protocol Phospholipids Remaining in Final Eluate

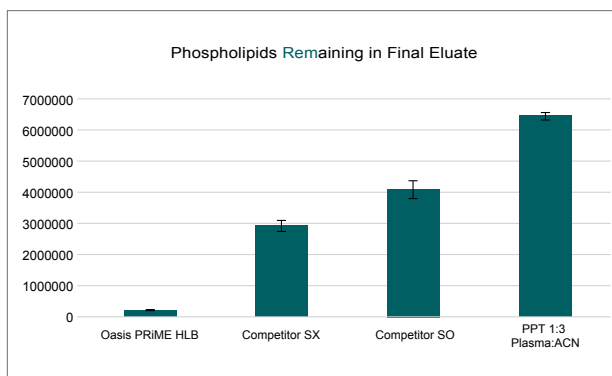

Fewer phospholipids remain in the final sample eluate with the Oasis PRiME HLB sorbent and 3-step protocol, compared to the final eluates using traditional 5-step protocol on the competitors' sorbents or protein precipitation (PPT). This removal is also more reproducible with Oasis PRiME HLB as indicated by the error bars ($n=5$).

Even Cleaner: The optimally designed sorbent removes more than 95% of common matrix interferences like proteins, salts, fats, and phospholipids

Choose the sample preparation method that meets your analytical needs.

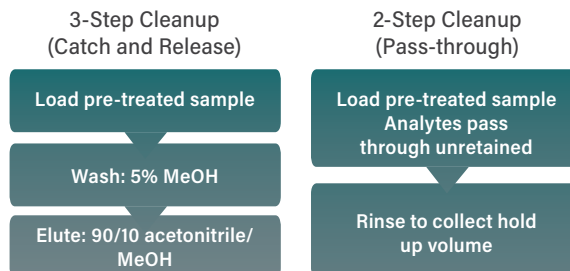

Use 3-step solid-phase extraction to remove the most matrix interferences, including salts, phospholipids, and proteins. This technique also allows for sample concentration/enrichment. Perfectly suited for routine bioanalytical sample cleanup.

Use 2-step sample cleanup to remove matrix interferences quickly if your beginning sample solution is high organic, and concentration and/or salt removal is not required. Perfectly suited for multiple residue veterinary drug screening in meats.

Ordering Information

Oasis PRiME HLB Sample Extraction Products

Description	Format	Qty.	P/N
Oasis PRiME HLB Cartridge	1 cc/30 mg	100/box	186008055
Oasis PRiME HLB Cartridge	3 cc/150 mg	100/box	186008717
Oasis PRiME HLB Cartridge	6 cc/500 mg	30/box	186008718
Oasis PRiME HLB Cartridge	3 cc/60 mg	100/pk	186008056
Oasis PRiME HLB Cartridge	6 cc/200 mg	30/pk	186008057
Oasis PRiME HLB Plus Light Cartridge	100 mg	50/box	186008886
Oasis PRiME HLB Plus Short Cartridge	335 mg	50/box	186008887
Oasis PRiME HLB μ Elution Plate	3 mg/96-well	1/pk	186008052
Oasis PRiME HLB Plate	10 mg/96-well	1/pk	186008053
Oasis PRiME HLB Plate	30 mg/96-well	1/pk	186008054

DID YOU KNOW...

Oasis Cartridges and Plates are available in two particle sizes (30 μ m and 60 μ m).

This allows you to select the appropriate product based on the viscosity and turbidity of your sample. For extraction of most plasma, serum, and human urine, choose the 30 μ m sorbent. For more viscous samples such as animal urine, excellent flow can be achieved using the 60 μ m sorbent in either cartridges or plates.

Ordering Information

Oasis HLB Sample Extraction Products

Description	Format	Particle Size	Qty.	P/N
Oasis HLB Cartridge	1 cc/10 mg	30 µm	100/box	186000383
Oasis HLB Cartridge	1 cc/30 mg	30 µm	100/box	WAT094225
Oasis HLB Cartridge	1 cc/30 mg	30 µm	1000/box	186003908
Oasis HLB Flangeless Cartridge	1 cc/30 mg	30 µm	100/box	186001879
Oasis HLB Cartridge with Gilson ASPEC Adapter	1 cc/10 mg	30 µm	500/box	186000988
Oasis HLB Cartridge with Gilson ASPEC Adapter	1 cc/30 mg	30 µm	500/box	WAT058882
Oasis HLB Cartridge	3 cc/60 mg	30 µm	100/box	WAT094226
Oasis HLB Cartridge	3 cc/60 mg	30 µm	1000/box	186007646
Oasis HLB Flangeless Cartridge	3 cc/60 mg	30 µm	100/box	186001880
Oasis HLB Cartridge with Gilson ASPEC Adapter	3 cc/60 mg	30 µm	500/box	WAT058883
Oasis HLB Cartridge	6 cc/200 mg	30 µm	30/box	WAT106202
Oasis HLB Cartridge	3 cc/400 mg	60 µm	100/box	186003849
Oasis HLB Cartridge	3 cc/540 mg	60 µm	100/box	186004134
Oasis HLB Flangeless Cartridge	3 cc/540 mg	60 µm	100/box	186003852
Oasis HLB Cartridge	6 cc/150 mg	30 µm	30/box	186003365
Oasis HLB Cartridge	6 cc/150 mg	60 µm	30/box	186003379
Oasis HLB Cartridge	6 cc/500 mg	60 µm	30/box	186000115
Oasis HLB Cartridge	12 cc/500 mg	60 µm	20/box	186000116
Oasis HLB Cartridge	20 cc/1 g	60 µm	20/box	186000117
Oasis HLB Cartridge	35 cc/6 g	60 µm	10/box	186000118
Oasis HLB Plus Short Cartridge	225 mg	60 µm	50/box	186000132
Oasis HLB Plus Light Cartridge	30 mg	30 µm	50/box	186005125
Oasis HLB Vac RC Cartridge	20 cc/30 mg	30 µm	50/box	186000382
Oasis HLB Vac RC Cartridge	20 cc/60 mg	30 µm	50/box	186000381
Oasis HLB Glass Cartridge	5 cc/200 mg	60 µm	30/box	186000683
Oasis HLB µElution Plate	2 mg/96-well	30 µm	1/pk	186001828BA
Oasis HLB Plate	5 mg/96-well	30 µm	1/pk	186000309
Oasis HLB Plate	10 mg/96-well	30 µm	1/pk	186000128
Oasis HLB Plate	30 mg/96-well	30 µm	1/pk	WAT058951
Oasis HLB Plate	60 mg/96-well	60 µm	1/pk	186000679

OASIS PRIME MCX

Oasis PRiME MCX is a highly efficient, orthogonal (reversed-phase and ion-exchange) solid-phase extraction product based on Oasis MCX technology.



SIMPLER: A defined, generic 3- or 4-step SPE protocol based on the water-wettable Oasis MCX strong cation-exchange/reversed-phase sorbent that does not require extensive method development. It allows targeted cleanup of basic compounds with $pK_a \geq 4.5$. Methods are patent pending.

CLEANER: Simpler methods remove up to 99% of phospholipids, a major cause of matrix effects, ion suppression, shorter column lifetimes, increased MS maintenance, and higher variability in LC-MS quantification. Oasis PRiME MCX is QC tested with this protocol for phospholipid removal.

FASTER: Cartridges and plates are designed with a manufacturing optimization to increase flow reproducibility across devices, making processing time more predictable. No conditioning and equilibration steps are required.

Oasis PRiME MCX 3- and 4-Step Protocols

3-Step Oasis PRiME MCX Protocol*

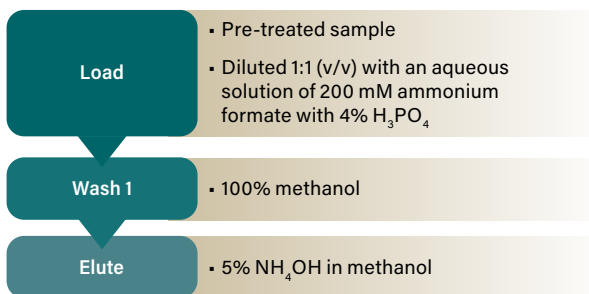

* The sample is diluted 1:1 with 200 mM ammonium formate with 4% H_3PO_4 , making a final concentration of 100 mM ammonium formate and 2% H_3PO_4 .

4-Step Oasis PRiME MCX Protocol**

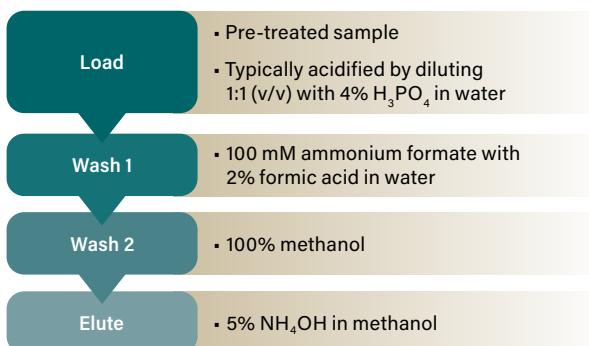

** Contains an extra wash step that can be used to remove additional matrix interferences if needed.

Oasis PRiME MCX methods are designed to capture and concentrate basic compounds while matrix interferences are removed from the sample. The 3-step method provides the simplest path to cleaner, while the 4-step method contains an additional wash step to remove even more matrix components, if needed.

OASIS MCX FOR BASIC COMPOUNDS

Obtain selective retention of basic drugs with cation-exchange groups on the sorbent surface. The Oasis MCX (Mixed-Mode Cation eXchange) Sorbent has a tightly controlled ion-exchange capacity (1 meq/g). There are no silanol groups to complicate the retention mode or method development. This novel, water-wettable, polymeric sorbent is stable from pH 0–14, making method development simple and fast.

Ordering Information

Oasis PRiME MCX Sample Extraction Products

Description	Format	Particle Size	Qty.	P/N
Oasis PRiME MCX Vac Cartridge	1 cc/30 mg	30 µm	100/box	186008917
Oasis PRiME MCX Vac Cartridge	3 cc/60 mg	30 µm	100/box	186008918
Oasis PRiME MCX Vac Cartridge	6 cc/150 mg	30 µm	100/box	186008919
Oasis PRiME MCX Plate	10 mg/96-well	30 µm	1/pk	186008915
Oasis PRiME MCX Plate	30 mg/96-well	30 µm	1/pk	186008916
Oasis PRiME MCX µElution Plate	2 mg/96-well	30 µm	1/pk	186008914

Ordering Information

Oasis MCX Sample Extraction Products (Cation Exchange)

Description	Format	Particle Size	Qty.	P/N
Oasis MCX Cartridge	1 cc/10 mg	30 µm	100/box	186004648
Oasis MCX Cartridge	1 cc/30 mg	30 µm	100/box	186000252
Oasis MCX Flangeless Cartridge	1 cc/30 mg	30 µm	100/box	186001881
Oasis MCX Cartridge	1 cc/30 mg	60 µm	100/box	186000782
Oasis MCX Cartridge	3 cc/60 mg	30 µm	100/box	186000254
Oasis MCX Flangeless Cartridge	3 cc/60 mg	30 µm	100/box	186001882
Oasis MCX Cartridge	3 cc/60 mg	60 µm	100/box	186000253
Oasis MCX Cartridge	6 cc/150 mg	30 µm	30/box	186000256
Oasis MCX Cartridge	6 cc/150 mg	60 µm	30/box	186000255
Oasis MCX Cartridge	6 cc/500 mg	60 µm	30/box	186000776
Oasis MCX Cartridge	20 cc/1 g	60 µm	20/box	186000777
Oasis MCX Cartridge	35 cc/6 g	60 µm	10/box	186000778
Oasis MCX Plus Short Cartridge	225 mg	60 µm	50/box	186003516
Oasis MCX Vac RC Cartridge	20 cc/60 mg	30 µm	50/box	186000261
Oasis MCX Vac RC Cartridge	20 cc/60 mg	60 µm	50/box	186000380
Oasis MCX µElution Plate	2 mg/96-well	30 µm	1/pk	186001830BA
Oasis MCX Plate	10 mg/96-well	30 µm	1/pk	186000259
Oasis MCX Plate	30 mg/96-well	30 µm	1/pk	186000248
Oasis MCX Plate	30 mg/96-well	60 µm	1/pk	186000250
Oasis MCX Plate	60 mg/96-well	60 µm	1/pk	186000678



APPLICATION AREA: Peptide Desalting and Enrichment

"The best part of (Oasis) PRiME line products is being able to load samples directly without pre-conditioning, which saves time and solvent. It is more "GREEN" than other products."

REVIEWER: Hui Chen

ORGANIZATION: University of Illinois at Chicago

OASIS MAX FOR ACIDIC COMPOUNDS

The Oasis MAX (Mixed-Mode Anion eXchange) sorbent has a tightly controlled ion-exchange capacity of 0.25 meq/g, ensuring reproducible SPE protocols for extraction of acidic compounds and metabolites from biological fluids. There are no silanol groups to complicate the retention mode or method development. This novel, water-wettable, polymeric sorbent is stable from pH 0–14, making method development simple and fast.

DID YOU KNOW...



When compared to other sample preparation techniques, SPE offers:

- Faster sample prep
- Compatibility with high throughput
- Greater recoveries
- Greater accuracy
- Powerful enrichment of analytes
- Additional selectivity and specificity

OASIS WCX FOR STRONG BASIC COMPOUNDS

The Oasis WCX (Weak Cation eXchange) SPE material provides better sample preparation for strong bases and quaternary amines. The retention mechanism is mixed mode (both ion exchange and reversed phase), which improves retention for all types of basic analytes, especially strong bases.

Ordering Information

Oasis MAX Sample Extraction Products (Anion Exchange)

Description	Format	Particle Size	Qty.	P/N
Oasis MAX Cartridge	1 cc/10 mg	30 µm	100/box	186004649
Oasis MAX Cartridge	1 cc/30 mg	30 µm	100/box	186000366
Oasis MAX Flangeless Cartridge	1 cc/30 mg	30 µm	100/box	186001883
Oasis MAX Cartridge	3 cc/60 mg	30 µm	100/box	186000367
Oasis MAX Cartridge	3 cc/60 mg	60 µm	100/box	186000368
Oasis MAX Flangeless Cartridge	3 cc/60 mg	30 µm	100/box	186001884
Oasis MAX Cartridge	6 cc/150 mg	30 µm	30/box	186000369
Oasis MAX Cartridge	6 cc/150 mg	60 µm	30/box	186000370
Oasis MAX Cartridge	6 cc/500 mg	60 µm	30/box	186000865
Oasis MAX Plus Short Cartridge	225 mg	60 µm	50/box	186003517
Oasis MAX Vac RC Cartridge	20 cc/30 mg	30 µm	50/box	186000372
Oasis MAX Vac RC Cartridge	20 cc/60 mg	30 µm	50/box	186000371
Oasis MAX Vac RC Cartridge	20 cc/60 mg	60 µm	50/box	186000378
Oasis MAX µElution Plate	2 mg/96-well	30 µm	1/pk	186001829
Oasis MAX Plate	10 mg/96-well	30 µm	1/pk	186000375
Oasis MAX Plate	30 mg/96-well	30 µm	1/pk	186000373
Oasis MAX Plate	60 mg/96-well	30 µm	1/pk	186001256
Oasis MAX Plate	60 mg/96-well	60 µm	1/pk	186001205

Ordering Information

Oasis WCX Sample Extraction Products (Weak Cation Exchange)

Description	Format	Particle Size	Qty.	P/N
Oasis WCX Cartridge	1 cc/10 mg	30 µm	100/box	186004650
Oasis WCX Cartridge	1 cc/30 mg	30 µm	100/box	186002494
Oasis WCX Cartridge	3 cc/60 mg	30 µm	100/box	186002495
Oasis WCX Cartridge	6 cc/150 mg	30 µm	30/box	186002498
Oasis WCX Cartridge	1 cc/30 mg	60 µm	100/box	186002496
Oasis WCX Cartridge	3 cc/60 mg	60 µm	100/box	186002497
Oasis WCX Cartridge	6 cc/500 mg	60 µm	30/box	186004646
Oasis WCX Plus Short Cartridge	225 mg	60 µm	50/box	186003518
Oasis WCX µElution Plate	2 mg/96-well	30 µm	1/pk	186002499
Oasis WCX 96-well Plate	10 mg/96-well	30 µm	1/pk	186002501
Oasis WCX 96-well Plate	30 mg/96-well	30 µm	1/pk	186002503

OASIS WAX FOR STRONG ACIDIC COMPOUNDS

The Oasis WAX (Weak Anion eXchange) SPE material provides sample preparation for strong acidic compounds. The retention mechanism is mixed mode (both ion exchange and reversed phase), which improves retention for strong acidic compounds.

Ordering Information

Oasis WAX Sample Extraction Products (Weak Anion Exchange)

Description	Format	Particle Size	Qty.	P/N
Oasis WAX Cartridge	1 cc/10 mg	30 µm	100/box	186004651
Oasis WAX Cartridge	1 cc/30 mg	30 µm	100/box	186002489
Oasis WAX Cartridge	3 cc/60 mg	30 µm	100/box	186002490
Oasis WAX Cartridge	6 cc/150 mg	30 µm	30/box	186002493
Oasis WAX Cartridge	1 cc/30 mg	60 µm	100/box	186002491
Oasis WAX Cartridge	3 cc/60 mg	60 µm	100/box	186002492
Oasis WAX Cartridge	6 cc/500 mg	60 µm	30/box	186004647
Oasis WAX Plus Cartridge	225 mg	60 µm	50/box	186003519
Oasis WAX µElution Plate	2 mg/96-well	30 µm	1/pk	186002500
Oasis WAX 96-well Plate	10 mg/96-well	30 µm	1/pk	186002502
Oasis WAX 96-well Plate	30 mg/96-well	30 µm	1/pk	186002504
Oasis WAX 96-well Plate	60 mg	30 µm	1/pk	186003915

DID YOU KNOW...



You can reduce non-specific binding, as well as sample loss, when working with therapeutic peptides on µElution plates.

Oasis 2 × 4 Method Development Protocol

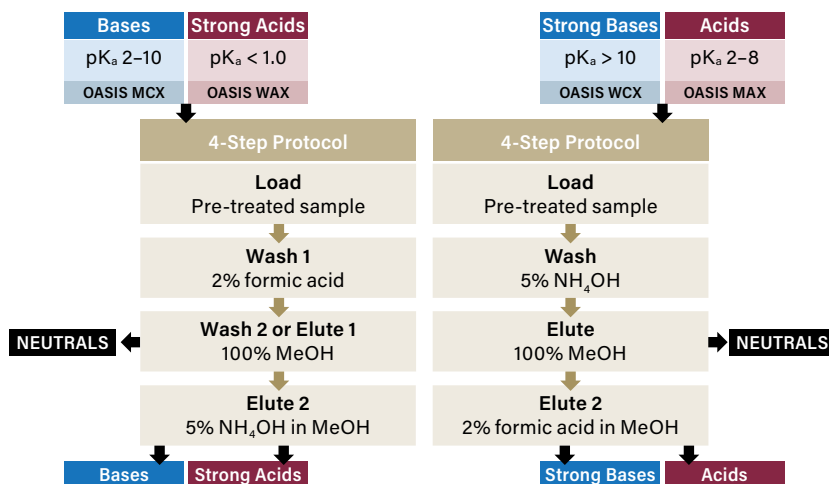

OASIS SORBENT SELECTION TOOLS FOR CONVENIENT METHOD DEVELOPMENT

The Oasis Sorbent Selection Plate and Cartridge Kits enable rapid development of SPE methods for LC-MS analysis. Having all four Oasis ion-exchange sorbents (MCX, MAX, WAX, and WCX) in a single plate or a cartridge kit is convenient for scouting the best methods to accomplish efficient isolation of unknown analytes, zwitterionic compounds, or mixtures of analytes with different retention/elution properties.

Ordering Information

Oasis Method Development Kits

Description	Format	Particle Size	P/N
Oasis Sorbent Selection Plate, 3 rows each: MCX, MAX, WCX, and WAX	10 mg/96-well	30 µm	186003249
Oasis µElution Sorbent Selection Plate, 3 rows each: MCX, MAX, WCX, and WAX	2 mg/96-well	30 µm	186004475
Oasis Sorbent Selection Cartridge Kit, 10 each: MCX, MAX, WCX, and WAX	1 cc/30 mg	30 µm	186003463
Oasis Sorbent Selection Flangeless Cartridge Kit, 10 each: MCX, MAX, WCX, and WAX	1 cc/10 mg	30 µm	186006344
Oasis Sorbent Selection Flangeless Cartridge Kit, 10 each: MCX, MAX, WCX, and WAX	1 cc/30 mg	30 µm	186006345

Oasis μ Elution 96-well Plates

Description	Particle Size	Qty.	P/N
Oasis PRIME HLB	—	1/pk	186008052
Oasis HLB	30 μ m	1/pk	186001828BA
Oasis PRIME MCX	30 μ m	1/pk	186008914
Oasis MCX	30 μ m	1/pk	186001830BA
Oasis MAX	30 μ m	1/pk	186001829
Oasis WCX	30 μ m	1/pk	186002499
Oasis WAX	30 μ m	1/pk	186002500
Oasis Method Development	30 μ m	1/pk	186004475
Peptide Method Development	30 μ m	1/pk	186004713

Oasis 96-well Plates

Description	Particle Size	5 mg/	10 mg/	30 mg/	60 mg/
		96-well	96-well	96-well	96-well
		1/pk	1/pk	1/pk	1/pk
Oasis PRIME HLB	—	—	186008053	186008054	—
Oasis HLB	30 μ m	186000309	186000128	WAT058951	—
Oasis HLB	60 μ m	—	—	—	186000679
Oasis PRIME MCX	—	—	186008915	186008916	—
Oasis MCX	30 μ m	—	186000259	186000248	—
Oasis MCX	60 μ m	—	—	186000250	186000678
Oasis MAX	30 μ m	—	186000375	186000373	186001256
Oasis MAX	60 μ m	—	—	—	186001205
Oasis WCX	30 μ m	—	186002501	186002503	—
Oasis WAX	30 μ m	—	186002502	186002504	186003915



Oasis Symbiosis/ Prospekt-2 Cartridges

Description	Format	Particle Size	Qty.	P/N
Oasis HLB Symbiosis/ Prospekt-2 Cartridge	1 \times 10 mm	30 μ m	96/box	186005781
Oasis HLB Symbiosis/ Prospekt-2 Cartridge	1 \times 20 mm	30 μ m	96/box	186005786
Oasis MCX Symbiosis/ Prospekt-2 Cartridge	1 \times 10 mm	30 μ m	96/box	186005782
Oasis MCX Symbiosis/ Prospekt-2 Cartridge	1 \times 20 mm	30 μ m	96/box	186004653
Oasis MAX Symbiosis/ Prospekt-2 Cartridge	1 \times 10 mm	30 μ m	96/box	186005783
Oasis MAX Symbiosis/ Prospekt-2 Cartridge	1 \times 20 mm	30 μ m	96/box	186004654
Oasis WCX Symbiosis/ Prospekt-2 Cartridge	1 \times 10 mm	30 μ m	96/box	186005784
Oasis WCX Symbiosis/ Prospekt-2 Cartridge	1 \times 20 mm	30 μ m	96/box	186004655
Oasis WAX Symbiosis/ Prospekt-2 Cartridge	1 \times 10 mm	30 μ m	96/box	186005785
Oasis WAX Symbiosis/ Prospekt-2 Cartridge	1 \times 20 mm	30 μ m	96/box	186004656

On-Line SPE Columns and Cartridge Columns

Description	Format	Particle Size	Qty.	P/N
Oasis HLB Column	2.1 \times 20 mm	5 μ m	1/pk	186002034
Oasis HLB Column	3.0 \times 20 mm	5 μ m	1/pk	186002037
Oasis HLB Column	3.9 \times 20 mm	5 μ m	1/pk	186002040
Oasis HLB Cartridge Column	3.9 \times 20 mm	5 μ m	1/pk	186001413
Oasis HLB Column	4.6 \times 20 mm	5 μ m	1/pk	186002043
Oasis HLB Column	2.1 \times 20 mm	15 μ m	1/pk	186002035
Oasis HLB Column	3.0 \times 20 mm	15 μ m	1/pk	186002038
Oasis HLB Column	3.9 \times 20 mm	15 μ m	1/pk	186002041
Oasis HLB Cartridge Column	3.9 \times 20 mm	15 μ m	1/pk	186001414
Oasis HLB Column	4.6 \times 20 mm	15 μ m	1/pk	186002044
Oasis HLB Column	2.1 \times 20 mm	25 μ m	1/pk	186002036
Oasis HLB Cartridge Column	2.1 \times 20 mm	25 μ m	1/pk	186000706
Oasis HLB Column	3.0 \times 20 mm	25 μ m	1/pk	186002039
Oasis HLB Column	4.6 \times 20 mm	25 μ m	1/pk	186002045
Oasis HLB Direct Connect Column	2.0 \times 15 mm	25 μ m	1/pk	186001792
Oasis MCX Column	2.1 \times 20 mm	30 μ m	1/pk	186002046
Oasis MCX Cartridge Column	2.1 \times 20 mm	30 μ m	1/pk	186002051
Oasis MCX Column	3.0 \times 20 mm	30 μ m	1/pk	186002047
Oasis MCX Column	3.9 \times 20 mm	30 μ m	1/pk	186002048
Oasis MCX Column	4.6 \times 20 mm	30 μ m	1/pk	186002049
Oasis MAX Column	2.1 \times 20 mm	30 μ m	1/pk	186002052
Oasis MAX Cartridge Column	2.1 \times 20 mm	30 μ m	1/pk	186002057
Oasis MAX Column	3.0 \times 20 mm	30 μ m	1/pk	186002053
Oasis MAX Column	3.9 \times 20 mm	30 μ m	1/pk	186002054
Oasis MAX Column	4.6 \times 20 mm	30 μ m	1/pk	186002055
Oasis WCX Column	2.1 \times 20 mm	30 μ m	1/pk	186002505
Oasis WCX Column	3.9 \times 20 mm	30 μ m	1/pk	186002507
Oasis WAX Column	2.1 \times 20 mm	30 μ m	1/pk	186002508
Oasis WAX Column	3.9 \times 20 mm	30 μ m	1/pk	186002509

Custom sorbents and configurations available upon request.

On-Line Solid-Phase Extraction (SPE) Cartridge

Description	Format	Particle Size	Qty.	P/N
Oasis WCX OSM Cartridge	1 \times 10 mm	30 μ m	96/pk	186005671

XBRIDGE OSM CARTRIDGES

The XBridge™ C₁₈ and C₈ sorbents use Waters' proprietary Ethylene Bridged Hybrid (BEH™) Technology to produce a sorbent with high mechanical strength and excellent stability for reversed-phase separations. These sorbents can provide separations with superior peak shape and high efficiency.

SPE COLUMNS FOR WATERS UPLC WITH ON-LINE SPE TECHNOLOGY



UPLC with On-Line SPE Technology combines automated sample handling, chromatographic media, and ultra-sensitive optical and mass spectrometry detection into an on-line SPE-LC-MS/MS solution. When paired with one of the three UPLC pressure-enabled on-line SPE column chemistries, you have the ability to extract a wide range of analytes.

This proven system and column chemistries dramatically streamlines the analysis of drinking water samples by providing analyte extraction, concentration, separation, and detection in one turnkey solution.

Ordering Information

XBridge OSM Cartridges

Description	Format	Particle Size	Qty.	P/N
XBridge C ₁₈ OSM Cartridge	1 × 10 mm	10 µm	96/pk	186005672
XBridge C ₈ OSM Cartridge	1 × 10 mm	10 µm	96/pk	186005673

Ordering Information

Oasis Bulk Sorbents

Description	Dimension	Particle Size	Qty.	P/N
Oasis HLB	—	30 µm/100 gm	—	186007549
Oasis HLB	—	30 µm/250 gm	—	186007550
Oasis MAX	—	30 µm/100 gm	—	186007553
Oasis MAX	—	30 µm/250 gm	—	186007554
Oasis MCX	—	30 µm/100 gm	—	186007551
Oasis MCX	—	30 µm/250 gm	—	186007552
Oasis HLB Glass Cartridge	—	60 µm	30/box	186000683
Oasis HLB Direct Connect HP Column	2.1 × 30 mm	20 µm	1/pk	186005231
XBridge C ₁₈ Direct Connect HP Column	2.1 × 30 mm	10 µm	1/pk	186005232
XBridge C ₈ Direct Connect HP Column	2.1 × 30 mm	10 µm	1/pk	186005233

Columns for On-Line Sample Manager (OSM)

Description	Dimension	Particle Size	Qty.	P/N
Oasis HLB Direct Connect HP Column	2.1 × 30 mm	20 µm	1/pk	186005231
XBridge C ₁₈ Direct Connect HP Column	2.1 × 30 mm	10 µm	1/pk	186005232
XBridge C ₈ Direct Connect HP Column	2.1 × 30 mm	10 µm	1/pk	186005233

OASIS GLASS CARTRIDGES FOR PPT DETECTION LEVELS

Oasis Glass Cartridges are available in a 5 cc (200 mg) configuration with Teflon Frits for trace analysis at parts per trillion (PPT) levels. Each lot is tested for the presence of bisphenol A and other phenols and phthalates, assuring that endocrine disruptors in water samples can be analyzed to PPT levels.

Ordering Information

Oasis HLB Glass Cartridge

Description	Dimension	Particle Size	Qty.	P/N
Oasis HLB Glass Cartridge	—	60 µm	30/box	186000683



Ostro Pass-Through Sample Preparation Product



The Simplest Way to Cleaner Samples: Ostro™ Pass-through 96-well Plate provides a novel solution for cleanup, requiring minimal-to-no method development, using a combination of filtration and sorbent interactions to produce cleaner samples in less time.

- Pass-through sample preparation technique
- Removes 95% of phospholipids and proteins
- For reproducible, consistent, and robust methods
- Increases throughput with easy-to-implement protocol



Reproducibility

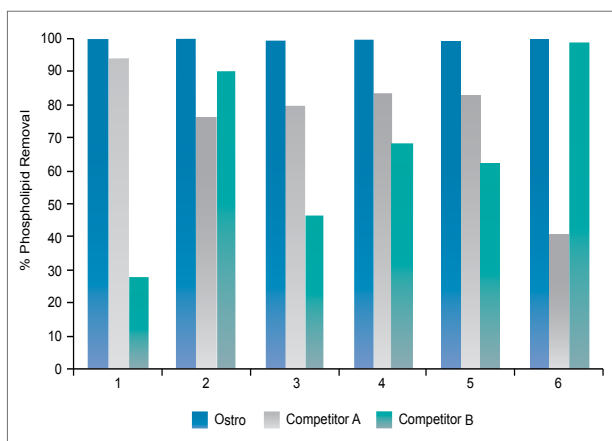

Comparative % removal of total phospholipids from six different lots of plasma using the Ostro (0.19% RSD), phospholipid removal plate from competitor A (24.5% RSD) and phospholipid removal plate from competitor B (40.9% RSD).

Recovery

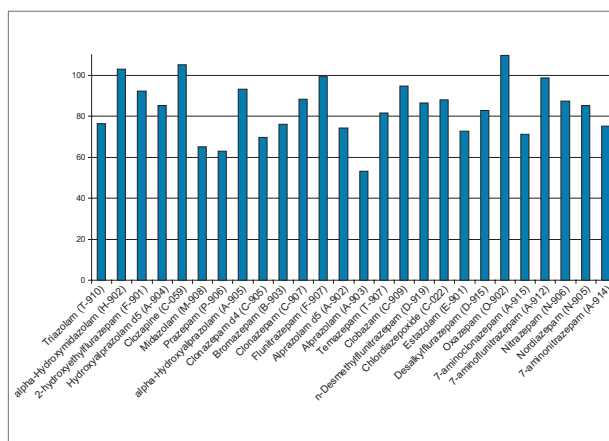

The Ostro Plate can be used with its standard protocol in a drug discovery setting for rapid sample cleanup. In this example, proteins and the vast majority of phospholipids were removed from a sample containing 26 structural analogs and metabolites while maintaining high analyte recovery.

Increased Instrument Uptime

Phospholipids can build up on your LC column and MS system. This leads to unpredictable, inaccurate results and necessitates extensive system cleaning and instrument downtime. Removing these contaminants before they enter your system provides increased instrument robustness, improved results, and maximum laboratory efficiency.

Ordering Information

Ostro Pass-Through Sample Preparation Plate

Description	Qty.	P/N
Ostro Protein Precipitation and Phospholipid Removal Plate, 25 mg	1/pk	186005518

Protocol

Minimizing method development time, the standard Ostro protocol will provide excellent results for a wide variety of acidic, basic, and neutral compounds.

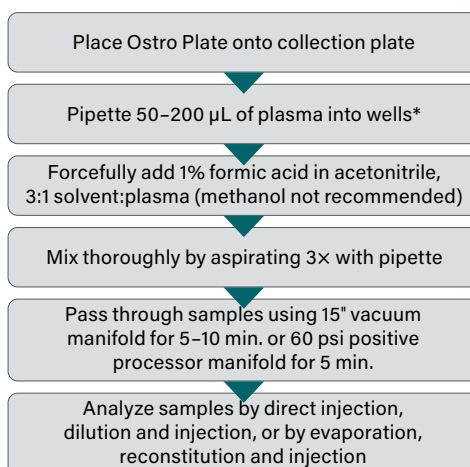

*For sample volumes 50 µL or less, a higher solvent to plasma ratio may be necessary.

Sep-Pak Solid-Phase Extraction (SPE) Products

The Most Referenced and Widely Used Sample Preparation Technology

Sep-Pak™ devices are recognized throughout the world and remain the most referenced SPE product for sample preparation. A diverse selection of formats and sorbents make Sep-Pak SPE Products ideally suited for all types of samples for GC, HPLC, and UPLC analysis methods.



Formats:

- Cartridges in both Vac syringes and Plus format devices
- 96-Well plate
- μ Elution plate

Chemistries:

- Reversed-Phase (silica-based)
- tC_2 -bonded phase with low hydrophobic characteristics
- C_8 -bonded phase with moderate hydrophobicity
- C_{18} -monofunctional bonded phase, a Waters original
- tC_{18} -tri-functional bonded phase with increased hydrolytic stability
- Reversed or Normal-Phase (less polar alternatives to silica)
- Amino Propyl (NH_2)-basic polar bonded phase
- Cyano Propyl (CN)-polar bonded phase
- Diol-neutral polar bonded phase
- PSA-Primary-Secondary Amine
- Normal-Phase
- Silica-polar surface used to adsorb analytes from non-polar solvents
- Alumina (A, B, N)- a highly active grade of alumina that is available in acidic, basic and neutral surface chemistries
- Florisil-polar, highly active, weakly basic sorbent for adsorption of low-to-moderate polarity species from nonaqueous solutions
- Ion-Exchange (silica-based)
- AccellPlus QMA-hydrophilic strong anion-exchanger with large pore size
- AccellPlus CM-hydrophilic weak cation-exchanger with large pore size
- Specialty
- PoraPak™ RDX-for analysis of explosives in ground and surface water, EPA-8330
- Sep-Pak Dry-anhydrous Na_2SO_4 for removal of residual water from non-aqueous extracts
- DNPH-Silica-for air analysis of aldehydes and ketones, EPA-TO-11A, ASTM D-5791
- XPoSure-for indoor air monitoring of aldehydes and ketones
- AC2-activated carbon used to concentrate pesticides and herbicides
- PS2-styrene-divinyl benzene polymer used to concentrate pesticides and herbicides
- Carbon Black/Amino Propyl-for pesticides from food
- Carbon Black/PSA-for concentrating pesticides from food
- Potassium Carbonate-for synthesis of radiopharmaceuticals

Sep-Pak Sorbent Selection Guide

Reversed Phase			
	Description	Applications	Properties
Sep-Pak C₁₈ Si(CH ₃) ₂ C ₁₈ H ₃₇	Hydrophobic, silica-based bonded phase used to adsorb analytes from aqueous solutions. Monofunctional bonding provides alternate selectivity versus tC ₁₈ .	<ul style="list-style-type: none"> Lipid fractionation; ganglioside isolation Organic acids in fruit juice, wine JPMHLW and CDFA official methods for pesticides in food Natural products AOAC methods for food colors, sugars 	<ul style="list-style-type: none"> Particle size: 55–105 μm Pore size: 125 Å Surface area: 325 m²/g Carbon load: 12% pH range: 2–8
Sep-Pak tC₁₈ SiC ₁₈ H ₃₇	Strongly hydrophobic, silica-based bonded phase used to adsorb analytes from aqueous solutions. Trifunctional bonding chemistry for increased hydrolytic stability.	<ul style="list-style-type: none"> JPMHLW official methods for pesticides in water JPMHLW official methods for odorants in water 	<ul style="list-style-type: none"> Particle size: 37–55 μm Pore size: 125 Å Surface area: 325 m²/g Carbon load: 17% pH range: 2–8
Sep-Pak C₈ Si(CH ₃) ₂ C ₈ H ₁₇	Moderately hydrophobic, silica-based bonded phase used in methods when less retention than that of HLB or C ₁₈ is required.	<ul style="list-style-type: none"> Drugs and their metabolites in biofluids Peptides in serum and plasma 	<ul style="list-style-type: none"> Particle size: 37–55 μm Pore size: 125 Å Surface area: 325 m²/g Carbon load: 9% pH range: 2–8
Sep-Pak tC₂ SiC ₂ H ₅	Weakly hydrophobic, silica-based bonded phase used in methods when less retention than that of C ₈ is required. Trifunctional bonding chemistry for increased hydrolytic stability.	<ul style="list-style-type: none"> Applications are similar to those of C₁₈ and C₈ 	<ul style="list-style-type: none"> Particle size: 37–55 μm Pore size: 125 Å Surface area: 325 m²/g Carbon load: 2.7% pH range: 2–8

Reversed or Normal Phase			
	Description	Applications	Properties
Sep-Pak Aminopropyl Si(CH ₂) ₃ NH ₂	Moderately polar, silica-based bonded phase with weakly basic surface. Can be used as a polar sorbent with different selectivity for acidic/basic analytes or as weak anion exchanges in aqueous medium below pH 8.	<ul style="list-style-type: none"> Phenols, phenolic pigments, natural products Petroleum fractionation Saccharides Drugs and drug metabolites JPMHLW official methods for pesticides in food 	<ul style="list-style-type: none"> Particle size: 55–105 μm Pore size: 125 Å Surface area: 325 m²/g Carbon load: 3.5% pH range: 2–8
Sep-Pak Cyanopropyl Si(CH ₃)(CH ₂) ₃ (CN)	Silica-based bonded phase with low hydrophobicity. Can be used as a less polar alternative to silica or as a less hydrophobic alternative to C ₁₈ or C ₈ .	<ul style="list-style-type: none"> Drugs and their metabolites Pesticides 	<ul style="list-style-type: none"> Particle size: 55–105 μm Pore size: 125 Å Surface area: 325 m²/g Carbon load: 6.5% pH range: 2–8
Sep-Pak Diol Si(CH ₂) ₃ OCH ₂ CH(OH)CH ₂ OH	Moderately polar, neutral, silica-based bonded phase. Used in normal-phase applications where acidic character of silica is undesirable or as a weakly hydrophobic phase in aqueous media.	<ul style="list-style-type: none"> Antibiotics in cosmetics Protein and peptide isolation by HIC (hydrophobic-interaction chromatography) 	<ul style="list-style-type: none"> Particle size: 37–55 μm Pore size: 300 Å Surface area: 100 m²/g Carbon load: 2% pH range: 2–8

AOAC = Association of Official Analytical Chemists; ASTM = American Society for Testing and Materials [International]; CDFA = California Department of Agriculture; EPA = U.S. Environmental Protection Agency; JPMHLW = Japanese Ministry of Health, Labour and Welfare; JPMOE = Japanese Ministry of the Environment; NIOSH = National Institute for Occupational Safety and Health.

Sep-Pak Sorbent Selection Guide *Continued*

Normal Phase			
	Description	Applications	Properties
Sep-Pak Silica SiO ₂	Polar sorbent binds analytes in non-aqueous solvents. Also used as an intermediate-strength cation exchanger in aqueous media and as a support for liquid-liquid partition separations.	<ul style="list-style-type: none"> Vitamins and food additives Lipid classification Synthetic organic compounds Natural products, plant pigments JPMHLW official methods for pesticides in food 	<ul style="list-style-type: none"> Particle size: 55–105 μm Pore size: 125 Å Surface area: 325 m²/g Activity: High (≤3.2% water)
Sep-Pak Alumina (A, B, N) Al ₂ O ₃	Highly surface-active polar, acidic (A), neutral (N), and basic (B) sorbents. Exhibits specific pi-electron interactions with aromatic hydrocarbons. Acidic and basic alumina are also low-capacity ion exchangers in aqueous media, unaffected by high-energy radioactivity.	<ul style="list-style-type: none"> Petroleum, synthetic crude oil fractionation (N) Radioactive compound isolation, isotope generators (A, B) Phospholipids, steroids, catecholamines (B) Food, feed additives (A, N), synthetic organic compounds (N) Pesticide, herbicide, priority pollutant isolation (N, B) Alternative to official AOAC and EPA methods (A, N, B) 	<ul style="list-style-type: none"> Particle size: 50–300 μm Pore size: 120 Å Activity: High, ≤1 on Brockmann scale (≤1.5% water) pH of 10% aqueous slurry: A: 4, N: 7.5, B: 10
Sep-Pak Florisil MgO·SiO ₂	Polar, highly active, weakly basic sorbent for the adsorption of low-to-moderately polar species from non-aqueous solutions.	<ul style="list-style-type: none"> AOAC and EPA official methods for pesticides JPMHLW official methods for pesticides in food Polychlorinated biphenyls (PCBs) in transformer oil 	<ul style="list-style-type: none"> Particle size: 50–200 μm Pore size: 60 Å Activity: High (≤2.5% water) pH of 10% aqueous slurry: 8.5
Ion Exchange			
	Description	Applications	Properties
Sep-Pak Accell Plus QMA Strong Anion Exchanger C(O)NH(CH ₂) ₃ N(CH ₃) ₃ ⁺ Cl ⁻	Silica-based, hydrophilic, strong anion exchanger with large pore size used to extract anionic analytes in aqueous and non-aqueous solutions.	<ul style="list-style-type: none"> Isolation of anionic proteins Acidic pigments in wine, fruit juices, food extracts Phenolic compounds Peptide pool fractionation Inorganic anions in environmental samples 	<ul style="list-style-type: none"> Particle size: 37–55 μm Pore size: 300 Å pH range: 2–9 Carbon load: 6% Ligand density: 220 μmol/g
Sep-Pak AccellPlus CM Weak Cation Exchanger COO ⁻ Na ⁺	Silica-based, hydrophilic, weak cation exchanger with large pore size used to extract cationic analytes in aqueous and non-aqueous solutions.	<ul style="list-style-type: none"> Isolation of cationic proteins Pesticides, herbicides Steroids Inorganic cations in environmental samples 	<ul style="list-style-type: none"> Particle size: 37–55 μm Pore size: 300 Å pH range: 2–9 Carbon load: 5.5% Ligand density: 350 μmol/g

AOAC = Association of Official Analytical Chemists; ASTM = American Society for Testing and Materials [International]; CDFA = California Department of Agriculture; EPA = U.S. Environmental Protection Agency; JPMHLW = Japanese Ministry of Health, Labour and Welfare; JPMOE = Japanese Ministry of the Environment; NIOSH = National Institute for Occupational Safety and Health.

Application Specific			
	Description	Applications	Properties
PoraPak RDX Divinylbenzene/ vinylpyrrolidone	For the analysis of explosives in surface and ground water. Meets or exceeds requirements of EPA Method 8330. Reduces use of organic solvent by 10-fold. PoraPak RDX is a divinylbenzene/vinylpyrrolidone copolymer.	<ul style="list-style-type: none"> EPA Method 8330 Nitroaromatics, Nitrosamines EPA Method 529 Explosives and Related Compounds 	<ul style="list-style-type: none"> Particle size: 125–150 µm Pore size: 200 Å
Sep-Pak DNPH Diphenylhydrazine coated on silica	Acidified dinitrophenylhydrazine reagent coated on silica used for collection of air samples. Aldehydes and ketones react <i>in situ</i> to form hydrazone derivatives; these are then eluted and quantitated by HPLC analysis.	<ul style="list-style-type: none"> EPA Method TO-11A; ASTM D5197 for carbonyl compounds in air JPMOE Official Methods for aldehydes: odor in outdoor air and in exhaust gas 	<ul style="list-style-type: none"> Particle size: 55–105 µm Pore size: 125 Å Recommended maximum capacity: 75 µg (2.5 µmol) formaldehyde/cartridge
Sep-Pak XPOSure Aldehyde sampler Diphenylhydrazine coated on silica	Acidified dinitrophenylhydrazine reagent coated on silica used for collection of air samples. Aldehydes and ketones react <i>in situ</i> to form hydrazone derivatives; these are then eluted and quantitated by HPLC analysis. Larger particle size optimized for low-pressure personal air monitors.	<ul style="list-style-type: none"> JPMHLW official methods for aldehydes in indoor air EPA Methods TO-11A and IP-6A, ASTM D5197 for carbonyl compounds in air NIOSH Method 2532 for glutaraldehyde in air 	<ul style="list-style-type: none"> Particle size: 500–1000 µm Pore size: 125 Å Recommended maximum capacity: 70 µg (2.3 µmol) formaldehyde/cartridge
Sep-Pak Ozone Scrubber Potassium iodide	Potassium iodide cartridge is used in series with Sep-Pak DNPH and XPOSure Aldehyde Sampler cartridges to remove ozone interferences.	<ul style="list-style-type: none"> EPA Method IP-6A and ASTM D5197 for carbonyl compounds in air 	<ul style="list-style-type: none"> Quantity: 1.4 g KI Capacity: 4.2 mmol ozone/cartridge (theoretical)
Sep-Pak Dry Anhydrous sodium sulfate	High-capacity desiccant used to remove residual water from normal-phase SPE extracts (in water-immiscible organic solvents).	<ul style="list-style-type: none"> General purpose 	<ul style="list-style-type: none"> Quantity: 2.85 g anhydrous Na₂SO₄ Theoretical capacity: 3.6 g H₂O
Sep-Pak PS2 Styrene-DVB copolymer	Very hydrophobic copolymer designed for multi-residue pesticide analysis in water samples.	<ul style="list-style-type: none"> JPMHLW official methods for pesticides in water and food EPA Method 537 	<ul style="list-style-type: none"> Particle size: 80 µm Quantity: 200 mg and 500 mg in Vac syringes, 300 mg in Plus short cartridges pH range 0–14
Sep-Pak AC2 Activated carbon	Highly hydrophobic, low ash content, activated carbon used to remove or enrich very polar organic molecules from water.	<ul style="list-style-type: none"> JPMHLW official method for 1,4-dioxane analysis in water Pesticides, herbicides, especially highly polar small molecules EPA Methods 522 and 541 	<ul style="list-style-type: none"> Particle size: 85 µm Quantity: 400 mg/cartridge pH range 1–12
Sep-Pak Carbon Black/Aminopropyl Carbon black aminopropyl silica	Two-layer sorbent bed used for pesticide cleanup in food matrices prior to GC analysis.	<ul style="list-style-type: none"> JPMHLW official methods for pesticides in food JPMHLW official method for propham 	<ul style="list-style-type: none"> Particle size: 37–105 µm (carbon black, top layer); 55–105 µm (aminopropyl silica, bottom layer) Quantity: 500 mg of each sorbent, separated by frit
Sep-Pak Carbon Black/PSA Primary-secondary amine silica	Two-layer sorbent bed used for pesticide cleanup in food matrices prior to GC analysis. PSA provides alternative selectivity compared to aminopropyl.	<ul style="list-style-type: none"> JPMHLW official methods for pesticides in food 	<ul style="list-style-type: none"> Particle size: 37–105 µm (carbon black, top layer); 37–55 µm (PSA, bottom layer) Quantity: 500 mg of each sorbent, separated by frit
Sep-Pak Potassium Carbonate K ₂ CO ₃	Potassium carbonate has been used as a mild base. When reacting with strong acids, it will produce salts, water, and carbon dioxide gas due to the carbonate breakdown.	<ul style="list-style-type: none"> Synthesis of radiopharmaceuticals 	<ul style="list-style-type: none"> Quantity: 2 g of sorbent in Plus long cartridge

Ordering Information

Sep-Pak Cartridge Selection Guide



	Plus Short	Plus Long	Plus Light	Classic Short	Classic Long	Vac 1 cc/50 mg	Vac 1 cc/100 mg	Vac RC/100 mg
	50/box	50/box	50/box	50/box	50/box	100/box	100/box	50/box
Sorbent	P/N Mass/Volume*	P/N Mass/Volume*	P/N Mass/Volume*	P/N Mass/Volume*	P/N Mass/Volume*	P/N Volume*	P/N Volume*	P/N Volume*
C ₁₈	WAT020515 360 mg/0.7 mL	WAT023635 820 mg/1.6 mL	WAT023501 130 mg/0.3 mL	WAT051910 360 mg/0.85 mL	—	WAT054955 0.13 mL	WAT023590 0.2 mL	WAT036935 0.2 mL
tC ₁₈	WAT036810 400 mg/0.8 mL	WAT036800 900 mg/1.4 mL	WAT036805 145 mg/0.4 mL	—	—	WAT054960 0.11 mL	WAT036820 0.25 mL	WAT043410 0.25 mL
C ₈	WAT036775 400 mg/0.8 mL	—	WAT036770 145 mg/0.4 mL	—	—	WAT054965 0.11 mL	WAT036785 0.25 mL	WAT043415 0.25 mL
tC ₂	WAT052720 400 mg/0.8 mL	—	WAT052725 145 mg/0.4 mL	—	—	—	WAT052710 0.25 mL	—
Silica	—	WAT020520 690 mg/1.6 mL	WAT023537 120 mg/0.4 mL	—	WAT051900 690 mg/2.0 mL	WAT054980 0.15 mL	WAT023595 0.25 mL	WAT036940 0.25 mL
Florisol	—	WAT020525 910 mg/1.4 mL	WAT023543 145 mg/0.3 mL	—	WAT051960 900 mg/1.7 mL	WAT054985 0.12 mL	WAT023600 0.2 mL	—
AccellPlus CM	WAT020550 360 mg/0.8 mL	—	WAT023531 130 mg/0.4 mL	WAT010910 360 mg/1.1 mL	—	—	WAT023625 0.25 mL	—
AccellPlus QMA	WAT020545 360 mg/0.8 mL	—	WAT023525 130 mg/0.4 mL	WAT010835 360 mg/1.1 mL	—	—	WAT023620 0.25 mL	WAT043460 0.25 mL
Alumina A	—	WAT020500 1710 mg/1.2 mL	WAT023549 280 mg/0.35 mL	—	WAT051800 1850 mg/1.8 mL	—	WAT023575 0.1 mL	—
Alumina B	—	WAT020505 1710 mg/1.2 mL	WAT023555 280 mg/0.35 mL	—	WAT051820 1850 mg/1.8 mL	—	WAT023580 0.1 mL	—
Alumina N	—	WAT020510 1710 mg/1.2 mL	WAT023561 280 mg/0.35 mL	—	WAT051810 1850 mg/1.8 mL	—	WAT023585 0.1 mL	—
Aminopropyl (NH ₂)	WAT020535 360 mg/0.7 mL	—	WAT023513 130 mg/0.3 mL	WAT010830 360 mg/0.85 mL	—	—	WAT023610 0.2 mL	WAT043475 0.2 mL
Cyanopropyl (CN)	WAT020540 360 mg/0.7 mL	—	WAT023507 130 mg/0.3 mL	WAT010823 360 mg/0.85 mL	—	WAT054975 0.13 mL	WAT023615 0.2 mL	—
PSA	186004538 360 mg/0.7 mL	—	186004578 130 mg/0.3 mL	186004560 360 mg/0.85 mL	—	186004562 0.1 mL	186004561 0.2 mL	186004567 0.2 mL
Diol	WAT020530 360 mg/0.8 mL	—	WAT023519 130 mg/0.4 mL	—	—	—	WAT023605 0.25 mL	—
Potassium Carbonate (K ₂ CO ₃)	—	186009005** 2 g	—	—	—	—	—	—

*Hold-up volume.

**Only in Plus Long cartridge, 100/box*

Sep-Pak 96-well Plates

Description	P/N
Sep-Pak tC ₁₈ , 25 mg Plate	186002319
Sep-Pak tC ₁₈ , 40 mg Plate	186002320
Sep-Pak tC ₁₈ , 100 mg Plate	186002321
Sep-Pak AccellPlus QMA, 100 mg Plate	186001917
Sep-Pak C ₁₈ , 40 mg Plate	186003966





	Vac 3 cc/200 mg	Vac 3 cc/500 mg	Vac RC/500 mg	Vac 6 cc/500 mg	Vac 6 cc/1 g	Vac 12 cc/2 g	Vac 20 cc/5 g	Vac 35 cc/10 g
	50/box	50/box	50/box	30/box	30/box	20/box	20/box	10/box
Sorbent	P/N Volume*	P/N Volume*	P/N Volume*	P/N Volume*	P/N Volume*	P/N Volume*	P/N Volume*	P/N Volume*
C ₁₈	WAT054945 0.42 mL	WAT020805 0.8 mL	WAT036945 0.8 mL	WAT043395 1.2 mL	WAT036905 2.0 mL	WAT036915 3.6 mL	WAT036925 8.0 mL	WAT043345 16.8 mL
tC ₁₈	WAT054925 0.34 mL	WAT036815 1.0 mL	WAT043425 1.0 mL	WAT036790 1.1 mL	WAT036795 1.9 mL	WAT043380 3.5 mL	WAT043365 7.8 mL	WAT043350 16.3 mL
C ₈	WAT054940 0.34 mL	WAT036780 1.0 mL	WAT043430 1.0 mL	WAT054525 1.1 mL	WAT054570 1.9 mL	WAT054615 3.5 mL	WAT054660 7.8 mL	WAT054700 16.3 mL
tC ₂	—	WAT052715 1.0 mL	—	—	WAT052705 1.9 mL	—	—	—
Silica	WAT054930 0.53 mL	WAT020810 1.2 mL	WAT036950 1.2 mL	WAT043400 1.2 mL	WAT036910 1.9 mL	WAT036920 3.9 mL	WAT036930 11.0 mL	WAT043355 23.4 mL
Florisil	—	WAT020815 0.8 mL	WAT043435 0.8 mL	WAT043405 1.2 mL	WAT043390 2.0 mL	WAT043385 3.6 mL	WAT043370 8.0 mL	WAT043360 16.8 mL
AccellPlus CM	—	WAT020855 1.1 mL	WAT054505 1.1 mL	WAT054545 1.2 mL	WAT054590 1.9 mL	WAT054635 3.5 mL	WAT054675 7.8 mL	WAT054720 16.3 mL
AccellPlus QMA	—	WAT020850 1.1 mL	WAT054500 1.1 mL	WAT054550 1.2 mL	WAT054595 1.9 mL	WAT054640 3.5 mL	WAT054680 7.8 mL	WAT054725 16.3 mL
Alumina A	—	WAT020820 0.4 mL	—	WAT054535 0.5 mL	WAT054580 0.8 mL	WAT054620 1.8 mL	WAT054670 3.9 mL	WAT054710 8.2 mL
Alumina B	—	WAT020825 0.4 mL	—	WAT054540 0.5 mL	WAT054585 0.8 mL	WAT054625 1.8 mL	WAT054665 3.9 mL	WAT054715 8.2 mL
Alumina N	—	WAT020830 0.4 mL	WAT043485 0.4 mL	WAT054530 0.5 mL	WAT054575 0.8 mL	WAT054630 1.8 mL	WAT043375 3.9 mL	WAT054705 8.2 mL
Aminopropyl (NH ₂)	—	WAT020840 0.8 mL	WAT054515 0.8 mL	WAT054560 1.2 mL	WAT054605 2.0 mL	WAT054650 3.6 mL	WAT054695 8.0 mL	WAT054740 16.8 mL
Cyanopropyl (CN)	WAT054935 0.42 mL	WAT020835 0.8 mL	—	WAT054555 1.2 mL	WAT054600 2.0 mL	WAT054645 3.6 mL	WAT054685 8.0 mL	WAT054730 16.8 mL
PSA	186004598 0.42 mL	186004536 0.8 mL	186004568 0.8 mL	186004563 1.2 mL	186004537 2.0 mL	186004564 3.6 mL	186004565 8.0 mL	186004566 16.8 mL
Diol ^a	—	WAT020845 1.0 mL	WAT054520 1.0 mL	WAT054565 1.1 mL	WAT054610 1.9 mL	WAT054655 3.5 mL	WAT054690 7.8 mL	WAT054735 16.3 mL
Potassium Carbonate (K ₂ CO ₃)	—	—	—	—	—	—	—	—

*Hold-up volume.

Sep-Pak 96-well μ Elution Plate

Description	P/N
Sep-Pak tC ₁₈ , 10 mg μ Elution Plate	186002318



ANATOMY OF SEP-PAK CARTRIDGES

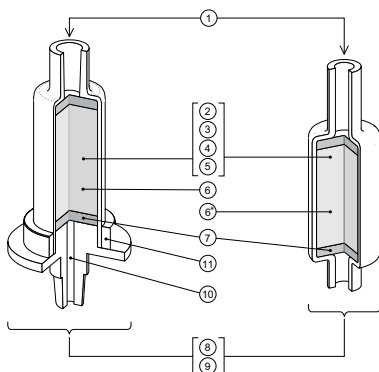

The Anatomy of Sep-Pak Plus and Classic Cartridge Design

1. Female Luer inlet accepts male Luer tip. Plus cartridge design can be stacked.
2. Highest quality sorbents designed and made specifically for sample preparation; clean, dry, reproducible in activity and capacity with optimal surface area, pore, and particle size distributions.
3. Broad range of sorbent surface activities available; each lot is tested under rigid specifications for chromatographic activity, retention, and selectivity.
4. Sorbent type and bed dimensions equal to corresponding Sep-Pak Classic Cartridges enable direct transfer of previously developed and published methods to new Plus design.
5. Weight of sorbent in each cartridge is controlled within +/- 5% of specification to assure reproducible performance.
6. Advanced bed formation to minimize voids and channels. Patented* Radial Compression Technology used to form homogeneous packed bed free of voids and channels.
7. Special blend of HD and UHMW polyethylenes used for 20 µm frits imparts excellent solvent resistance, extremely low extractables level, and good flow properties. Frit also acts as depth filter for small amounts of sample debris.
8. Polyethylene body has excellent solvent resistance. All body parts are quality tested to verify extremely low level of UV-absorbing extractables. Plus design is molded for precise dimensions making it suitable for automated equipment.
9. Cartridges are sealed in a special polyfoil pouch to protect product integrity, sorbent activity, and purity.
10. Male Luer outlet has reduced internal volume for minimal sample hold up.
11. Color-coded ring compresses and seals the cartridge and identifies sorbent.

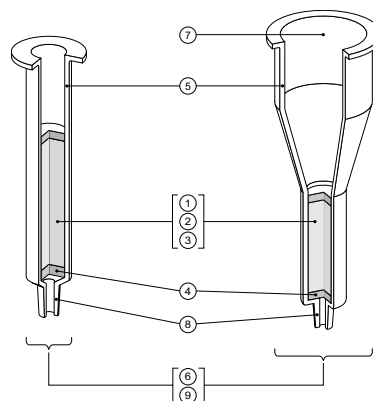

The Anatomy of Sep-Pak Vac and Vac RC Cartridge Designs

12. Highest quality sorbents design and made specially for sample preparation; clean, dry, reproducible in activity and capacity, with optimal surface area, pore, and particle size.
13. Broad range of sorbent surface activities available; each lot is tested under rigid specifications for chromatographic activity, retention, and selectivity.
14. Weight of sorbent in each cartridge is controlled within +/- 5% of specification to assure reproducible performance.
15. Special blend of HD and UHMW polyethylenes used for 20 µm frits.
16. Molded, medical-grade, polypropylene body.
17. Cartridges are sealed in a special polyfoil pouch to protect product integrity, sorbent activity, and purity.
18. Integral reservoir approximately 20 mL, robotic compatible.
19. Outlet make Luer tip.
20. Color-coded labeling in the cartridge to identify the sorbent.

*P.D. McDonald, C.W. Rausch, Radial Compression of Packed Beds, U.S. Patent #4,250,035 (1981); Great Britain # 1,568,700 (1976); Canada # 1,101,785 (1981); Japan # 1,400,983 (1987); Sweden # 450,750 (1987); Germany # 2,655,650 (1988); other patents pending.

GENERAL EXTRACTION PROTOCOLS FOR SEP-PAK CARTRIDGES

Normal-Phase Chromatography with Sep-Pak Cartridges

To perform normal-phase chromatography with Sep-Pak Cartridges, use a gradient of non-polar solvents with polar silica, florisil, NH₂, diol, CN, alumina A, B, or N as a sorbent*.

1. You may condition the cartridge with 6–10 hold-up volumes of non-polar solvent, usually the sample solvent.
2. Load the sample into the cartridge.
3. Elute unwanted components with a non-polar solvent.
4. Elute the first component of interest with a polar solvent.
5. Elute remaining components of interest with progressively more polar solvents.
6. When you recover all of your components, discard the used cartridge in an appropriate manner.

*Depending upon your chromatographic conditions, you may also use CN as a packing material for normal-phase chromatography.

Reversed-Phase Chromatography with Sep-Pak Cartridges

To perform reversed-phase chromatography with Sep-Pak Cartridges, use a gradient of strongly-to-weakly polar solvents with non-polar C₁₈, tC₁₈, C₈, tC₈, diol, NH₂, or CN as a sorbent.

1. Solvate the bonded phase with 6–10 cartridge hold-up volumes of methanol or acetonitrile. Flush the cartridge with 6–10 hold-up volumes of water or buffer. Do not allow the cartridge to dry out.
2. Load the sample dissolved in a strongly polar solvent.
3. Elute unwanted components with a strongly polar solvent.
4. Elute weakly held components of interest with a less polar solvent.
5. Elute more tightly bound components with progressively more non-polar solvents.
6. When you recover all of your components, discard the used cartridge in an appropriate manner.

Ion-Exchange Chromatography with Sep-Pak Cartridges

To perform ion-exchange chromatography with Sep-Pak Cartridges, use a gradient of pH or ionic strength with AccellPlus CM, AccellPlus QMA, or NH₂ as a sorbent.

1. Condition the cartridge with 6–10 held-up volumes of deionized water or weak buffer.
2. Load the sample dissolved in a solution of deionized water or buffer.

3. Elute unwanted weakly bound components with a weak buffer.
4. Elute the first component of interest with a stronger buffer (change the pH or ionic strength).
5. Elute other components of interest with progressively stronger buffers.
6. When you recover all of your components, discard the used cartridge in an appropriate manner.

General Elution Protocol for Normal-Phase Chromatography on Sep-Pak Cartridges (Silica, Alumina, Florisil, Diol, NH₂)

1. Load sample.
2. Use progressively more polar solvents to elute first and second components of interest.
3. You may condition cartridge with non-polar solvent.
4. Elute unwanted components.
5. Elute first component of interest (Component 1).
6. Elute second component of interest (Component 2).
7. Discard the used cartridge.

General Elution Protocol for Reversed-Phase Chromatography on Sep-Pak Cartridges (C₁₈, CN)

1. Load sample.
2. Use progressively stronger solvents to elute first and second components of interest.
3. Solvate the bonded phase with methanol, then flush with water and buffer.
4. Elute unwanted components.
5. Elute first component of interest (Component 1).
6. Elute second component of interest (Component 2).
7. Discard the used cartridge.

General Elution Protocol for Ion-Exchange Chromatography on Sep-Pak Cartridges (NH₂, AccellPlus QMA, AccellPlus CM)

1. Load sample.
2. Use progressively stronger buffers (changing pH or ionic strength) to elute first and second components of interest.
3. Condition cartridge with water or buffer.
4. Elute unwanted component(s) with more water or buffer.
5. Elute first component of interest (Component 1).
6. Elute second component of interest (Component 2).
7. Discard the used cartridge.

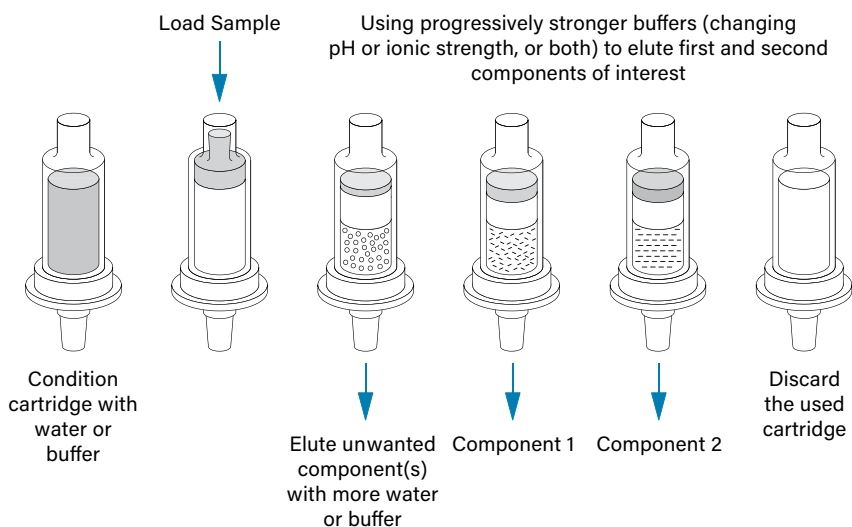
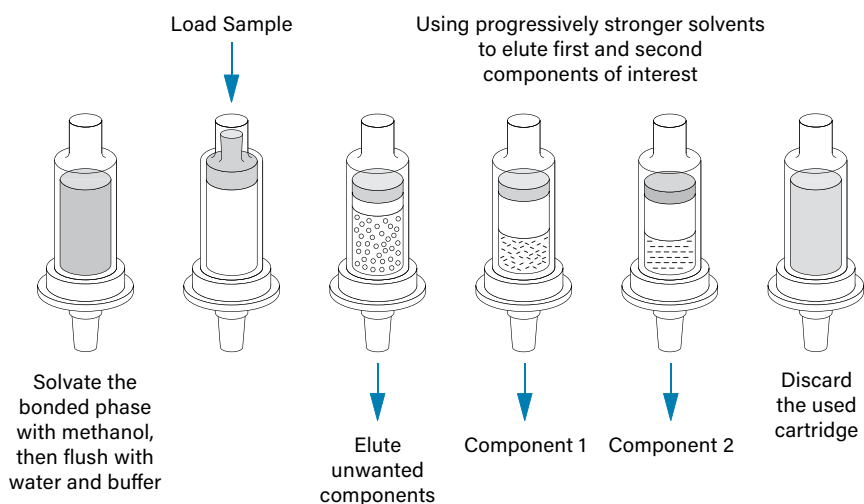
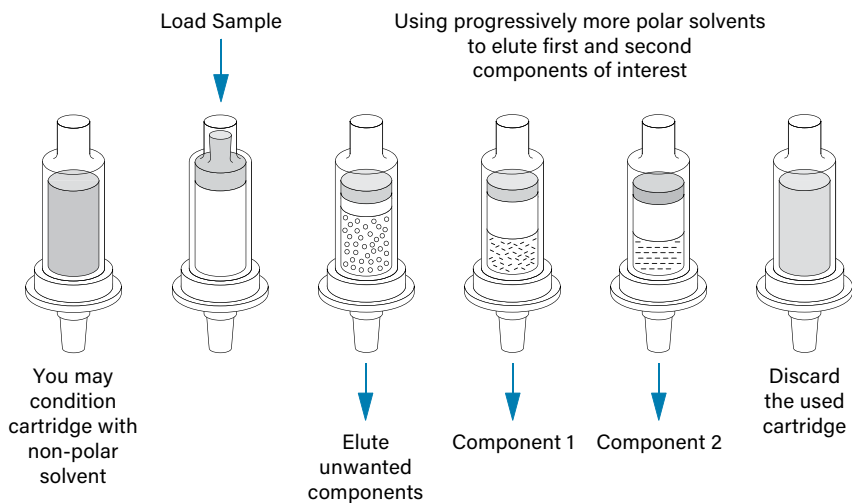

Advantages of Sep-Pak DNPH-Silica Cartridges

These cartridges provide you with significant advantages when compared to other techniques, such as liquid impingers, for the analysis of aldehydes and ketones. In addition, a new high speed, high resolution HPLC application has been developed to provide excellent quantitation capability in the low parts-per-billion range.

- Sep-Pak DNPH-Silica Cartridges meet the requirements of EPA Method TO-11A and ASTM-D-5791-1
- Results from impingers and these cartridges are in excellent agreement
- Solvent consumption, solvent exposure, and hazardous waste disposal costs are reduced
- Sep-Pak DNPH-Silica Cartridges provide superior convenience and reproducibility, making them ideal for field sampling and process monitoring applications
- Sep-Pak DNPH-Silica Cartridges can save time and increase productivity
- Increased safety

Ordering Information



Sep-Pak DNPH-Silica Cartridge

Description	Qty.	P/N
Sep-Pak DNPH-Silica Short Body Cartridge	20/box	WAT037500
Sep-Pak DNPH-Silica Long Body Cartridge	20/box	WAT039550

Ozone Scrubber Cartridges

Ozone has been shown to interfere with the analysis of carbonyl compounds in air samples that have been drawn through cartridges containing silica coating with 2,4-dinitrophenylhydrazine (DNPH). Ozone Scrubber Cartridges are designed to remove this ozone interference.

These disposable devices are intended for use in series combination with Sep-Pak DNPH-Silica Cartridges or XPoSure Aldehyde Sampler Cartridges.

Ordering Information



Sep-Pak Ozone Scrubber

Description	Qty.	P/N
Sep-Pak Ozone Scrubber	20/box	WAT054420

Sep-Pak XPoSure Aldehyde Sampler Cartridges for Monitoring Aldehydes in Indoor Air

Based on an extension of Waters' DNPH coating technology, Sep-Pak XPoSure Aldehyde Sampler Cartridges are the most sensitive active samplers available today.

Ordering Information



Sep-Pak XPoSure Aldehyde Sampler Cartridge

Description	Qty.	P/N
Sep-Pak XPoSure Aldehyde Sampler Cartridge	20/box	WAT047205

PoraPak RDX Sep-Pak Extraction Cartridge for the Analysis of Explosives in Surface and Ground Waters

Designed to meet or exceed the QA/QC requirements of EPA Method 8330, the PoraPak RDX Sep-Pak Extraction Cartridge is ideal for environmental testing laboratories supporting Department of Defense remediation programs.

Ordering Information

PoraPak RDX Cartridges and Accessories

Description	Qty.	P/N
PoraPak RDX Cartridges	30/box	WAT047220
Tubing, Tefzel, 1/8 in. O.D. × 0.040 in. I.D.	10 ft.	WAT023344
Sep-Pak Vac Adapter	12/box	WAT054260
60 cc Sep-Pak Reservoir	12/box	186005587
Male-Male Adapter	100/box	WAT024310

Sep-Pak Dry SPE Cartridge

Sep-Pak Dry Cartridges are packed with 2.85 g of anhydrous sodium sulfate. These cartridges are designed to remove residual water from the SPE extract.



Ordering Information

Sep-Pak Dry Cartridge

Description	Qty.	P/N
Sep-Pak Dry Cartridge	50/box	WAT054265

Sep-Pak Specialty Chemistries

Description	Mass/Volume/Type	Qty.	P/N
Air Testing			
Sep-Pak DNPH-Silica Cartridge	350 mg/0.7 mL/Plus Short	20/box	WAT037500
Sep-Pak DNPH-Silica Cartridge	800 mg/1.6 mL/Plus Long	20/box	WAT039550
Sep-Pak XPoSure Aldehyde Sampler Cartridge	350 mg/0.7 mL/Plus Short	20/box	WAT047205
Sep-Pak Ozone Scrubber Cartridge	1.4 g/1.6 mL/Plus Short	20/box	WAT054420
Food, Environmental, and Biological Testing			
PoraPak RDX Cartridge	500 mg/1 mL/6 cc Vac	30/box	WAT047220
Sep-Pak Dry Cartridge	2.85 g/1.6 mL/Plus Long	50/box	WAT054265
Sep-Pak Carbon Black/Aminopropyl Cartridge	500 mg carbon black, 500 mg aminopropyl/1.4 mL/6 cc Vac	30/box	186003369
Sep-Pak Carbon Black/PSA Silica Cartridge	500 mg carbon black, 500 mg PSA/1.4 mL/6 cc Vac	30/box	186004590
Sep-Pak AccellPlus QMA Carbonate Cartridge	150 mg/0.4 mL/Plus Light	50/box	186004051
Sep-Pak AccellPlus QMA Carbonate Plus Light Cartridge	46 mg/0.15 mL/Plus Light	50/box	186004540
Sep-Pak PS2	6 cc Vac syringe 500 mg sorbent weight, 30/pk	00/box	WAT200610
Sep-Pak AC2	Plus Short cartridge, 400 mg sorbent per cartridge, 50/pk	00/box	JJAN20229

Certified Sep-Pak Solid-Phase Extraction (SPE) Cartridges

As a pioneer in SPE, Waters has advanced SPE performance and quality by offering Certified Sep-Pak Sample Preparation Products. By manufacturing these devices to strict performance and cleanliness specifications, we ensure that the detection limits and performance of your analytical methods will not be compromised by interfering substances commonly found in SPE hardware.

Improve Workflow and Reduce Solvent Waste

Certified Sep-Pak Sample Preparation Devices are available in the most commonly used formats and sorbents to allow easy integration into your sample preparation protocol. Reduced background interferences reduce solvent waste by eliminating unnecessary solvent pre-washing steps that are often required for trace residue methods.

Manufacturing

Our world-class manufacturing facilities strive to improve quality expectations for SPE product performance. We manufacture under the highest quality standard in the industry including ISO 9001, ISO 13485, and current Good Manufacturing Practices (CGMP). Each Certified Sep-Pak product is thoroughly QC tested.

Sorbent specifications based on:

- Contaminants including hydrocarbons and other environmental contaminants
- Sorbent functionality including:
 - ligand density
 - particle size distribution
 - surface activity
- Chromatographic performance

Assembly specifications based on:

- Frit and barrel dimensional tolerance
- Chromatographic testing of total residual extractables including:
 - hydrocarbons
 - plasticizers
 - antioxidants
- Sorbent bed voiding
- Consistent sample flow characteristics



Comparison of Extracted Interference Levels in Organochlorine Pesticide Analysis at 1 ppm

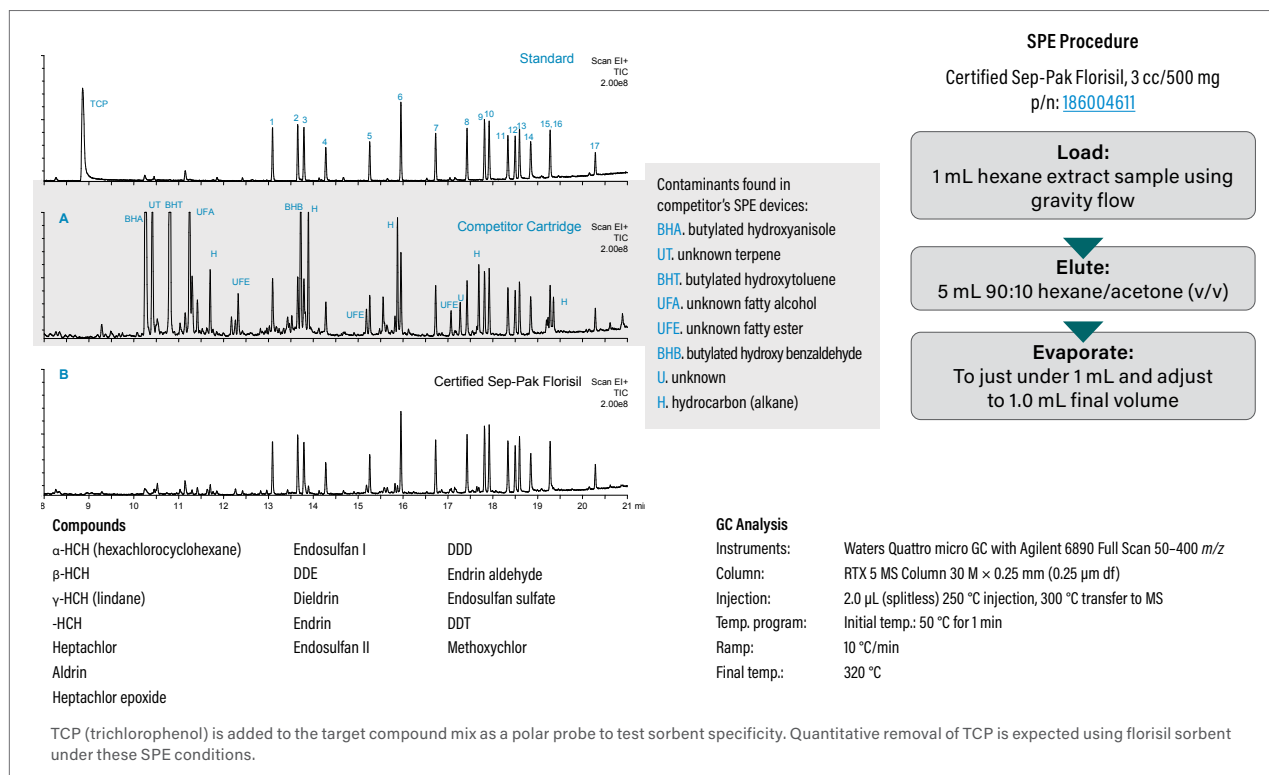

CERTIFIED SEP-PAK SORBENT SELECTION GUIDE

C₁₈

- Silica-based, trifunctionally-bonded octadecyl sorbent
- High carbon load provides excellent hydrolytic stability for a wide range of samples
- Strong hydrophobic sorbent used to adsorb analytes of even weak hydrophobicity from aqueous solutions
- Typical applications include drugs and their metabolites in serum, plasma or urine; desalting of peptides; trace organics in environmental water samples; organic acids in beverages



Silica

- Unbonded, highly activated silica stationary phase
- A polar sorbent for analyte isolation from non-polar solvents like hydrocarbons and less polar esters and ethers
- Analyte retention can occur through hydrogen bonding or dipole-dipole interactions in non-aqueous samples
- Silica provides a slightly acidic surface for moderate cation-exchange interactions in aqueous samples
- Elution with more polar solvents like polar esters, ethers, alcohols, acetonitrile, or water



Ordering Information

C₁₈ Sorbent

	3 cc/200 mg	3 cc/500 mg	6 cc/500 mg	6 cc/1 g
Sorbent	50/box	50/box	30/box	30/box
C ₁₈	186004618	186004619	186004620	186004621

Silica Sorbent

	3 cc/200 mg	3 cc/500 mg	6 cc/500 mg	6 cc/1 g
Sorbent	50/box	50/box	30/box	30/box
Silica	186004614	186004615	186004616	186004617

Alumina (A, B, N)

- Alumina is very similar to silica; however, the alumina surface tends to be slightly more stable under high pH conditions than unfunctionalized silica
- The aluminum oxide surface provides an extremely polar surface for analyte retention and has properties of a Lewis acid
- Depending on the sorbent's surface treatment, alumina is available in three forms: Alumina A, Alumina B, and Alumina N
- Alumina exhibits specific interactions with the π -electrons of aromatic hydrocarbons, making it useful for applications like crude oil fractionation
- Acidic and basic grades can be used as low-capacity ion exchangers



Florisil

- Very-polar, highly-active, weakly-basic sorbent for adsorption of low-to-moderate polarity species from non-aqueous solutions
- Specifically designed for the adsorption of pesticides using official AOAC, EPA, and JPMHLW regulated methods
- Applications include polychlorinated biphenyls (PCBs) in transformer oil



Ordering Information

Florisil Sorbent

	3 cc/500 mg	6 cc/500 mg	6 cc/1 g
Sorbent	50/box	30/box	30/box
Florisil	186004611	186004612	186004613

Ordering Information

Alumina (A, B, N) Sorbents

	3 cc/500 mg	6 cc/500 mg	6 cc/1 g
Sorbent	50/box	30/box	30/box
Alumina A	186004602	186004603	186004604
Alumina B	186004605	186004606	186004607
Alumina N	186004608	186004609	186004610

DID YOU KNOW...

Strategies for Isolating and Cleaning Up Analytes of Interest

Two general SPE strategies are implemented for isolating and cleaning up sample components of interest. A retention-cleanup-elution strategy is frequently used when the compounds of interest are present in levels too low for accurate and precise quantitation. Concentration of dilute samples and trace enrichment of compounds are achieved by this strategy. A pass-through cleanup strategy may be chosen when the desired sample component is present at a high concentration. However, no sample enrichment occurs when a pass-through cleanup strategy is used.

PoraPak Rxn Cartridges for Post-Synthesis Cleanup



PoraPak products are polymer based for superior cleanup of synthetic reactions. They are available in two chemistries:

- PoraPak Rxn CX (strong cation-exchange sorbent)
- PoraPak Rxn RP (reversed-phase sorbent)

PoraPak Rxn Sorbents are available in fritted, syringe-barrel devices in 6, 20, and 60 cc volumes. The resins are also sold in bulk units, and custom configurations are available on request.

New Solutions for Faster Results

PoraPak Rxn Sorbents are based on copolymers that exhibit these properties:

- Hard material that does not develop increasing back pressure with flow
- Little swelling or shrinking across a range of solvents and pH extremes
- Low hydraulic resistance enables flow by gravity
- pH extreme tolerance without dissolution or hydrolysis, both limitations of silica-based sorbents



This combination of physical and chemical properties makes PoraPak Rxn Cartridges ideal for synthesis cleanup. The polymers characteristics and particle size maintain gravity-, pressure-, or vacuum-assisted flow; even when reaction mixtures contain precipitate that may contribute additional resistance to flow. The sample will still pass through the cartridge.

The polymer used in PoraPak Rxn Products is resistant to shrinking or swelling in the organic solvents typically used in synthetic reactions. Tests with the following solvents demonstrate that the packed bed maintains good flow properties:

- DCE
- THF
- DMF
- DMSO
- DCM
- Acetone

Some medicinal chemists are familiar with silica-based chromatographic products for reaction cleanup. One of the limitations of these silica-based ion-exchange materials is pH. Silica will dissolve at high pH, while bonded phases are hydrolyzed at low pH; both conditions result in loss of sample and/or impurities (silica and bonded phase) collected in product fractions. PoraPak Rxn polymer-based chromatographic phases are stable at extreme pH. This feature permits using pH as a very powerful tool to create a separation, particularly in ion-exchange mode.

Providing Separations Solutions

Waters is highly respected worldwide for its expertise in chromatography. Coupled with our ability to seamlessly link critical instrumentation, chemistries, separation technologies, and software, this expertise puts us in a unique position to deliver value-added solutions to our customers.

Manufacturing

Our world-class manufacturing facilities are continuously expanded and upgraded to keep pace with market demand for our new and existing products. We manufacture under the highest quality standards in the industry, including ISO 9001, ISO 13485, and Current Good Manufacturing Practices (cGMP).

Ordering Information

PoraPak Rxn Cartridges and Bulk Material

Description	PoraPak Rxn CX	PoraPak Rxn RP
6 cc Flanged Cartridges, 400 mg, 30/pk	186004541	186004545
6 cc Flangeless Cartridges, 400 mg, 30/pk	186004542	186004546
20 cc Cartridges, 2 g, 20/pk	186004543	186004547
60 cc Cartridges, 5 g, 10/pk	186004544	186004548
Bulk, 200 mL Container	186004569	186004570

Vacuum Manifold and Accessories

VACUUM MANIFOLD FOR USE WITH SPE CARTRIDGES

The vacuum manifold has the capacity to process up to 20 samples simultaneously. The extraction manifold has enhanced features designed for use with conventional silica-based, SPE cartridges as well as modifications that allow you to take full advantage of the unique performance characteristics of our Oasis Extraction Cartridges.

This manifold offers:

- Precision-machined Delrin cover with alignment posts for quick and easy alignment with test tube rack.
- Vacuum gauge placement on cover, not in fluid path, allows for quick and easy waste removal at bottom by vacuum.
- Enhanced vacuum control valve designed for use with Oasis Extraction Cartridges, allows for a quick and momentary rise in vacuum above the frit bubble point at the touch of a finger.
- High-purity, polypropylene needle valves and needle tips with minimum dead volume (opening and closing the valves is required to prevent silica-based SPE cartridges from drying out).

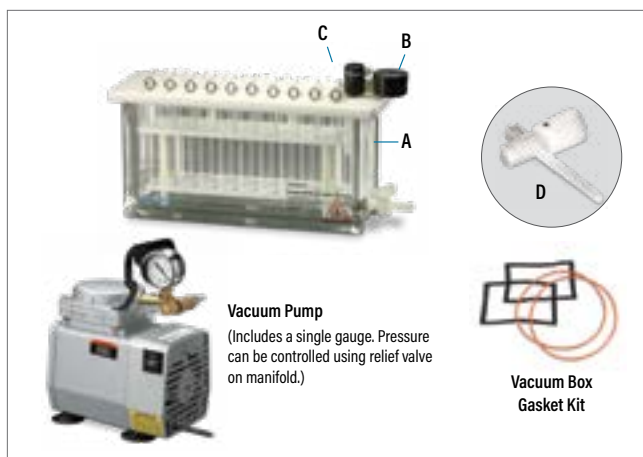

Ordering Information

Spare Parts for Waters Extraction Manifolds

Description	Qty.	P/N
Needle Valves (required when using silica-based SPE cartridges; not required for use with extraction cartridges)	20/pk	WAT200685
Needle Tips	20/pk	WAT200691
Cover, 20 Position without Gauge Assembly	1/pk	186008990
Gauge Assembly, Vacuum	1/pk	WAT200687
Reservoir, Glass with Outlet Valve	1/pk	186008991
Outlet Valve Kit	1/pk	WAT200689
Gasket for Cover	1/pk	WAT200690
Ejector Tool	1/pk	WAT058839
Luer Plugs	25/pk	WAT058851
Rubber Ball Ring (for vacuum gauge assembly)	1/pk	WAT058840
Reversible Vial Rack for 1 mL or 4 mL Autosampler Vials	1/pk	186009084
2 mL Vial Rack for Manifold	1/pk	186009083
13 × 75 mm Test Tube Rack	1/pk	186008994
13 × 100 mm Test Tube Rack	1/pk	186008995
16 × 75 mm Test Tube Rack	1/pk	186008996
16 × 100 mm Test Tube Rack	1/pk	186008997
Reservoir, 30 cc (for Plus, Vac, and Classic Cartridges)	48/pk	WAT011390
Reservoir, 60 cc (for Plus, and Vac Cartridges)	12/pk	186005587
Adapter, Male-Male Luer (for Classic Cartridges)	100/pk	WAT024310
Adapter (to attach reservoir to 1, 3, and 6 cc Vac Cartridges)	12/pk	WAT054260
Adapter (to attach reservoir to 12, 20, and 35 cc Vac Cartridges)	10/pk	WAT048160
Vacuum Pump (110 V, 60 Hz)	1/pk	725000417
Vacuum Pump (220 V, 50 Hz)	1/pk	725000604

Manifold and Accessories for Extraction Plate

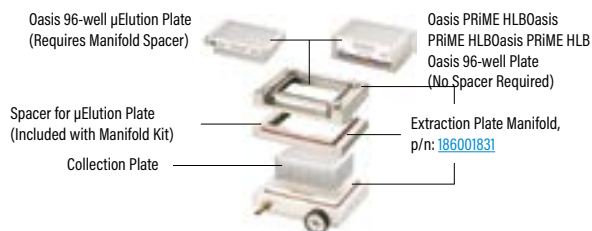

Description	Qty.	P/N
Extraction Plate Manifold for Oasis 96-well Plates	1/pk	186001831
Extraction Plate Manifold Kit A (includes extraction plate manifold, reservoir tray, sealing cap, and 350 μ L sample collection plate)	—	WAT097944
Extraction Plate Manifold Kit B (as Kit A, with 1 mL sample collection plate)	—	WAT097945
Extraction Plate Manifold Kit C (as Kit A, with 2 mL sample collection plate)	—	WAT097946
Disposable Reservoir Tray	25/box	WAT058942
Sample Collection Plate, 350 μ L	50/box	WAT058943
Sample Collection Plate, 2 mL	50/box	WAT058958
Sealing Cap for 96-well Collection Plate	50/box	WAT058959
Vacuum Pump (115 V, 60 Hz)	1/pk	725000417
Vacuum Pump (240 V, 50 Hz)	1/pk	725000604
Vacuum Box Gasket Kit (Kit contains: 2 foam top gaskets, 2 orange O-rings)	—	186003522

Manifold and Accessories for Extraction Cartridges

Description	Qty.	P/N
Waters Extraction Manifold, 20-position without rack (includes 20 needle tips, 25 plugs, and ejector tool)	1/pk	186008998
Waters Extraction Manifold, 20-position (complete with rack for 13 × 75 mm tubes)	1/pk	WAT200606
Waters Extraction Manifold, 20-position (complete with rack for 13 × 100 mm tubes)	1/pk	WAT200607
Waters Extraction Manifold, 20-position (complete with rack for 16 × 75 mm tubes)	1/pk	WAT200608
Waters Extraction Manifold, 20-position (complete with rack for 16 × 100 mm tubes)	1/pk	WAT200609
Female Luer Plugs	100/pk	WAT044385
30 cc Reservoir	48/pk	WAT011390
60 cc Reservoir	12/pk	186005587
Reservoir Adapters for 1, 3, and 6 cc Cartridges	12/pk	WAT054260
Reservoir Adapters for 12, 20, and 35 cc Cartridges	10/pk	WAT048160
Male-Male Adapter	100/pk	WAT024310
Male Luer Plugs	100/pk	WAT044395

Sep-Pak Cartridge Connections Kit

This kit contains a selection of the most commonly needed fittings, adapters, valves, and tubing for use with Sep-Pak Cartridges.



Ordering Information

Sep-Pak Cartridge Connections Kit

Description	P/N
Sep-Pak Connections Kit	WAT011400

SEP-PAK CARTRIDGE ACCESSORIES

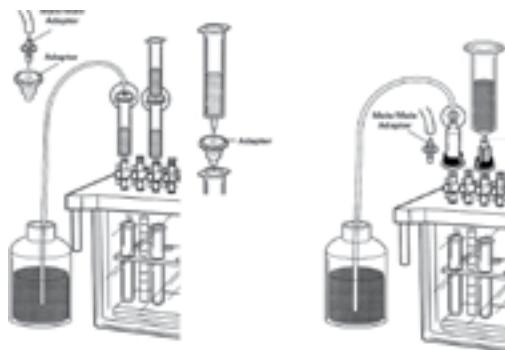

Ordering Information

Accessories for Extraction Columns and Cartridges

Description	Qty.	P/N
Holder Kit for 2.1 × 20 mm Cartridge Column	1/pk	186000262
Holder Kit for 3.9 × 20 mm Cartridge Column	1/pk	WAT046910
Extraction Column Connector	1/pk	WAT082745
Inline Pre-Column Filter Kit	1/pk	WAT084560
Replacement Filters	5/pk	WAT005139
Vacuum Pump (115 V, 60 Hz)	1/pk	725000417
Vacuum Pump (240 V, 50 Hz)	1/pk	725000604
Reservoir, 30 cc (for Plus and Vac Cartridges)	48/pk	WAT011390
Reservoir, 60 cc (for Plus and Vac Cartridges)	12/pk	186005587
Adapter, Male-Male Luer (for Classic Cartridges)	100/pk	WAT024310
Adapter (to attach reservoir to 1, 3, and 6 cc Vac Cartridges)	12/pk	WAT054260
Adapter (to attach reservoir to 12, 20, and 35 cc Vac Cartridges)	10/pk	WAT048160
2 mL Vial Rack for Manifold	1/pk	186009083

DisQuE Sample Preparation Solutions for QuEChERS



QuEChERS (an acronym for Quick, Easy, Cheap, Effective, Rugged, and Safe) methods offer a simple and straightforward sample preparation technique ideal for multi-residue analysis for pesticides, veterinary drugs, and mycotoxins in a wide variety of food and agricultural products. DisQuE Dispersive Sample Preparation Products are conveniently packaged with pre-weighed sorbents and buffers in pouches and tubes as described in regulatory methods and protocols.



These products offer several advantages over traditional sample preparation techniques:

- Simplified QuEChERS protocols
- Decreased sample preparation time
- Efficient and cost-effective sample preparation
- Consistent, high-quality sorbents and packaging

DisQuE KITED SOLUTIONS

Complete solutions and kitted methods add value to your laboratory function by addressing the need for simple, easy-to-follow protocols that require very little training.



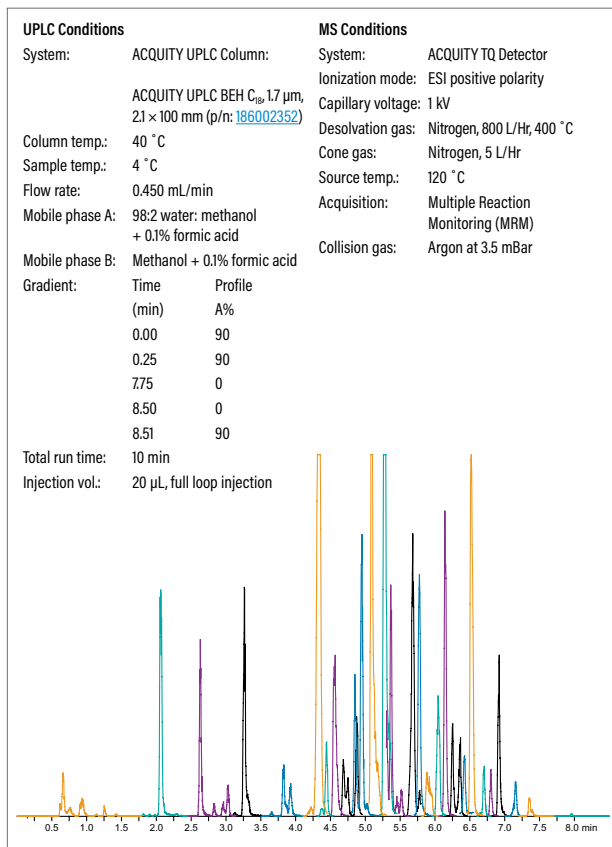

Waters offers several different versions of pre-packaged QuEChERS kits which conform to both AOAC and CEN protocols.

402 Pesticide Residues at 10 ppb ng/g In One 10-Minute Run



Ordering Information

DisQuE Dispersive Sample Preparation Kits

Description	P/N
DisQuE Kits	
 DisQuE AOAC Dispersive SPE Kit-Pouch Format <ul style="list-style-type: none"> ■ Pouch: 1.5 g sodium acetate and 6 g MgSO₄ ■ 50 mL Tube: Empty ■ 2 mL Tube: 150 mg MgSO₄ and 50 mg PSA 	176002922
 DisQuE CEN Dispersive SPE Kit-Pouch Format <ul style="list-style-type: none"> ■ Pouch: 1 g trisodium citrate dihydrate, 0.5 g disodium hydrogencitrate sesquihydrate, 1 NaCl and 4 g MgSO₄ ■ 50 mL Tube: Empty ■ 2 mL Tube: 150 mg MgSO₄, 25 mg PSA, and 25 mg C₁₈ 	176002923
 DisQuE AOAC Dispersive SPE Kit <ul style="list-style-type: none"> ■ Tube 1: 50 mL tube containing: 1.5 g sodium acetate and 6 g MgSO₄ ■ Tube 2: 2 mL tube containing: 150 mg MgSO₄ and 50 mg PSA 	176001676
 DisQuE CEN Dispersive SPE Kit <ul style="list-style-type: none"> ■ Tube 1: 50 mL tube containing: 1 g trisodium citrate dihydrate, 0.5 g disodium hydrogencitrate sesquihydrate, 1 g NaCl and 4 g MgSO₄ ■ Tube 2: 2 mL tube containing: 150 mg MgSO₄, 25 mg PSA, and 25 mg C₁₈ 	176001903

DisQuE Extraction and Cleanup Tubes and Pouches

DisQuE Extraction and Cleanup Tubes and Pouches are available separately for customized applications and method development. The salts contained in the 50 mL tubes are also available in a pouch format for greater flexibility. The cleanup tubes are available in a standard 2 mL size as well as a 15 mL size for sample enrichment.

Ordering Information

DisQuE Dispersive Sample Preparation Products

Description	P/N
Individual Extraction Tubes (Tube 1)	
50 mL Empty Tube for QuEChERS Extraction	186006814
DisQuE 50 mL Tube/ AOAC-Acetate	DisQuE 50 mL tube containing: 1.5 g sodium acetate and 6 g MgSO ₄ , 100/pk 186004571
DisQuE 50 mL Tube/ CEN-Citrate	DisQuE 50 mL tube containing: 1 g trisodium citrate dihydrate, 0.5 g disodium hydrogencitrate sesquihydrate, 1 g NaCl and 4 g MgSO ₄ , 100/pk 186004837

Description	P/N
Individual Extraction Pouch	
DisQuE Pouch	1.5 g sodium acetate, 6 g MgSO ₄ , 50/pk 186006812
	4 g MgSO ₄ , 1 g NaCl, 1 g trisodium citrate dehydrate, 0.5 g disodium hydrogencitrate sesquihydrate, 50/pk 186006813

DisQuE Cleanup Tubes (Tube 2)

AOAC Method		
Description	Tube Size	P/N
DisQuE Tube containing: 150 mg MgSO ₄ and 50 mg PSA, 100/pk	2 mL	186004572
DisQuE Tube containing: 150 mg MgSO ₄ , 50 mg PSA and 50 mg C ₁₈ , 100/pk	2 mL	186004830
DisQuE Tube containing: 900 mg MgSO ₄ and 300 mg PSA, 50/pk	15 mL	186008077
DisQuE Tube containing: 900 mg MgSO ₄ , 300 mg PSA and 300 mg C ₁₈ , 50/pk	15 mL	186008078
DisQuE Tube containing: 1200 mg MgSO ₄ and 400 mg PSA, 50/pk	15 mL	186008072
DisQuE Tube containing: 1200 mg MgSO ₄ , 400 mg PSA and 400 mg C ₁₈ , 50/pk	15 mL	186008073
DisQuE Tube containing: 1200 mg MgSO ₄ , 400 mg PSA, 400 mg C ₁₈ , and 400 mg GCB, 50/pk	15 mL	186008074

DisQuE Cleanup Tubes (Tube 2)

CEN Method		
Description	Tube Size	P/N
DisQuE Tube containing: 150 mg MgSO ₄ and 25 mg PSA, 100/pk	2 mL	186004831
DisQuE Tube containing: 150 mg MgSO ₄ , 25 mg PSA, and 25 mg C ₁₈ , 100/pk	2 mL	186004832
DisQuE Tube containing: 150 mg MgSO ₄ , 25 mg PSA, and 2.5 mg GCB, 100/pk	2 mL	186008076
DisQuE Tube containing: 900 mg MgSO ₄ , 150 mg PSA, 50/pk	15 mL	186004833
DisQuE Tube containing: 900 mg MgSO ₄ , 150 mg PSA, and 150 mg C ₁₈ , 50/pk	15 mL	186004834

DisQuE Cleanup Tubes (Tube 2)

Specialty Cleanup Tubes		
Description	Tube Size	P/N
DisQuE Tube containing: 150 mg MgSO ₄ and 50 mg C ₁₈ , 100/pk	2 mL	186008075
DisQuE Tube containing: 150 mg MgSO ₄ , 25 mg PSA, 25 mg C ₁₈ , and 7 mg GCB, 100/pk	2 mL	186008071
DisQuE Tube containing: 900 mg MgSO ₄ , 450 mg PSA, 300 mg C ₁₈ , and 50 mg GCB, 50/pk	15 mL	186008079
DisQuE Tube containing: 150 mg MgSO ₄ , 50 mg PSA, 30 mg C ₁₈ , and 30 mg alumina-N, 100/pk	2 mL	186008081
DisQuE Tube containing: 750 mg MgSO ₄ , 250 mg PSA, 150 mg C ₁₈ , and 150 mg alumina-N, 50/pk	15 mL	186008080



Bulk Sorbents

Description	P/N
Graphitized Carbon Black, 25 g Bottle	186004835
C ₁₈ , 100 g Bottle	WAT035672

Waters/Pall Life Sciences Sample and Solvent Filtration Products

Filtration of samples and solvents is a preventative maintenance procedure that saves lab time and money. Filtration provides immediate protection for the components of column and instrumentation by minimizing down time.

Waters/Pall Life Sciences Filters have been certified for compliance, which means they have been designed and developed to assist customers in complying with their regulatory and quality objectives.

Waters carries a broad range of Pall Life Sciences Filter Products, a range of different membranes for solvent and sample compatibility, and a variety of devices for various filtration applications.



Literature References

Title	Literature Code
The First LC-MS Certified Filter with Extremely Low Levels of Extractables	720007168EN
Acrodisc wwPTFE Syringe Filters Versus Syringe Filters with Hydrophilic Polypropylene (GHP) Membranes White Paper	720007171EN

Choosing the Right Filter for Your Application

To choose the right filter, you need to consider sample characteristics, volume, pore size; and decide if the sample may require prefiltration because it is laden with particulate matter.

Membrane Choices

- **Acrodisc MS wwPTFE Syringe Filters:** Designed specifically to extend the lifespan of LC columns used for LC-MS analyses without adding significant extractables and with minimal analyte adsorption. These filters are constructed with a water-wettable polytetrafluoroethylene (wwPTFE) membrane in high density polyethylene (HDPE) housings.
- **wwPTFE Acrodiscs:** Water wettable, hydrophilic, polytetrafluoroethylene membranes are a "next generation", all-purpose, hydrophilic membrane for aqueous, acidic, basic, non-aggressive organic, and aggressive organic solutions. It offers low protein binding and low levels of UV-absorbing extractables.
- **Nylon Acrodiscs:** This hydrophilic membrane works well with both aqueous and organic solvents. Nylon is particularly suitable for high-pH samples but should be avoided in any protein recovery applications.
- **wwPTFE Acrodisc GF and Nylon Acrodisc GF:** Designed with a glass fiber prefilter over the membrane for hard to filter samples laden with particulate matter
- **Glass Fiber (GF) Acrodiscs:** Can be used alone or as a prefilter with another Acrodisc in series
- **Acrodisc PVDF (LC):** Hydrophilic polyvinylidene fluoride (PVDF) membranes good for aqueous and organic solvents
- **Acrodisc PTFE (CR):** Hydrophobic, polytetrafluoroethylene (PTFE) membranes are recommended for use with non-aqueous solvents. Organic-based, highly acidic or basic samples and solvents
- **Supor PES (IC) Filters for Ion Chromatography:** Polyethersulfone (PES) IC filters are certified to contain low ionic backgrounds for ion chromatography

Concerned about particulate matter in your sample?

Step 1: What is the nature of your sample?

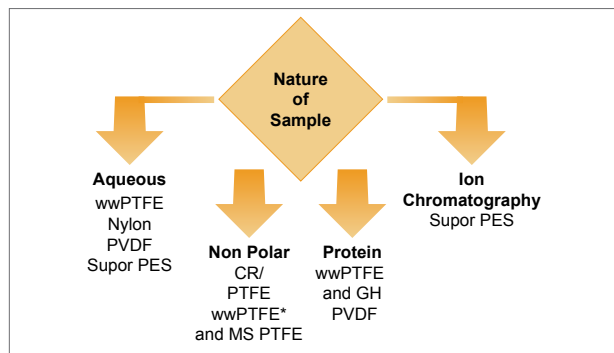

*For samples with laden particulate that are difficult to filter, it is best to use a syringe filter with a glass fiber prefilter over the membrane. These are available in wwPTFE and Nylon.

Step 2: What micron size are the particles in the column you are using?

Column	Pore Size of Filter
>3 µm	0.45 µm
<3 µm	0.20 µm

Step 3: What is the volume of your sample?

Volume	Acrodisc Size	Hold Up Volume
<2 mL	4 mm	<10 µL
<10 mL	13 mm minispikes	<14 µL
<10 mL	13 mm male Luer	<30 µL
<100 mL	25 mm	<100 µL

Example 1: 1.5 mL of aqueous sample to be filtered for injection on a 5 µm column

Step	Question	Answer	Choice
1	Sample	Aqueous	GHP and others
2	Column's particle size	5 µm	0.45 µm
3	Volume	1.5 mL	13 mm or 25 mm

Choice: Membrane 0.45 µm wwPTFE Acrodisc in 4 mm or larger. You can also use the Nylon, PVDF or Supor PES (other choices of hydrophilic membranes under the aqueous sample path). In terms of device size, if you are injecting only a few µL of sample on the column, you can use any device size. The 13 and 25 mm Acrodiscs have hold up volumes of at most 100 µL, leaving plenty of filtered sample for the application.

FILTER DESIGN AND MEMBRANE CHOICES

		PVDF (LC) Membrane	Glass Fiber Media	Nylon Membrane	Supor PES (IC) Membrane	RPTFE (CR) Membrane	wwPTFE Membrane
Media Materials							
ACIDS	Acetic acid, glacial	R	R	N	R	R	R
	Acetic acid, 90%	R	R	N	R	R	R
	Acetic acid, 30%	R	R	L	R	R	R
	Acetic acid, 10%	R	R	R	R	R	R
	Hydrochloric acid, conc. (35%)	R	R	R	R	R	R
	Hydrochloric acid, 6 N (20%)	R	R	R	R	R	R
	Hydrochloric acid, 1 N (3.3%)	R	R	R	R	R	R
	Nitric acid, conc. (67%)	R	L	N	N	R	R
	Nitric acid, 6 N (27%)	R	—	L	—	R	R
	Sulfuric acid, conc. (96%)	N	R	N	N	R	R
Sulfuric acid, 6 N (16%)	—	R	L	—	R	R	
ALCOHOLS	Amyl alcohol	R	R	L	N	R	R
	Benzyl alcohol	R	N	N	N	R	R
	Butanol	R	R	L	R	R	R
	Ethanol	R	R	R	R	R	R
	Isopropanol	R	R	L	R	R	R
	Methanol	R	R	L	R	R	R
BASES	Ammonium hydroxide, 3 N (5.7%)	N	R	R	R	R	R
	Ammonium hydroxide, 6 N (11.4%)	N	R	L	R	R	R
	Potassium hydroxide, 3 N (15%)	N	N	R	R	R	R

FILTER DESIGN AND MEMBRANE CHOICES *Continued*

		PVDF (LC) Membrane	Glass Fiber Media	Nylon Membrane	Supor PES (IC) Membrane	PTFE (CR) Membrane	wwPTFE Membrane
Media Materials							
BASES	Sodium hydroxide, 3 N (11%)	N	—	R	R	R	R
	Sodium hydroxide, 6 N (22%)	N	—	L	R	R	R
ESTERS	Amyl acetate	R	R	L	R	R	R
	Butyl acetate	R	R	R	R	R	R
	2-Ethoxyethyl acetate	L	R	—	R	R	R
	Ethyl acetate	R	R	R	N	R	R
	Isopropyl acetate	R	R	N	R	R	R
	Methyl acetate	R	R	N	N	R	R
ETHERS	Ethyl ether	R	R	N	R	R	R
	Tetrahydrofuran	N	L	R	N	R	R
	Tetrahydrofuran/water (50/50,v/v)	—	—	—	—	R	R
GLYCOLS	Ethylene glycol	R	R	R	R	R	R
	Glycerol	R	R	R	R	R	R
	Propylene glycol	R	R	—	R	R	R
AROMATIC HYDROCARBONS	Benzene	R	R	R	R	R	R
	Toluene	R	R	L	R	R	R
	Xylene	R	R	L	R	R	R
HALOGENATED HYDROCARBONS	Carbon tetrachloride	R	R	R	R	R	R
	Chloroform	R	R	R	N	R	R
	Ethylene dichloride	R	R	N	N	R	R
	Methylene chloride	R	R	R	N	R	R
	Tetrachloroethylene	R	R	L	R	R	R
KEYTONES	Acetone	N	R	L	N	R	R
	Cyclohexanone	L	R	R	N	R	R
	Methyl ethyl ketone (MEK)	N	R	L	N	R	R
	Methyl isobutyl ketone	N	R	L	R	R	R
OILS	Cottonseed	R	R	R	R	R	R
	Peanut	R	R	R	R	R	R
MISCELLANEOUS	Acetonitrile	R	R	—	R	R	R
	Dimethyl formamide (DMF)	N	R	N	N	R	R
	Dimethyl sulfoxide (DMSO)	N	R	—	N	R	R
	Formaldehyde, 37%	R	R	R	R	R	R
	Formaldehyde, 4%	R	R	R	R	R	R
	Hexane, dry	R	R	L	L	R	R
	Kerosene	R	R	L	R	R	R
	Pyridine	N	R	N	N	R	R
	18 Megohm water	R	R	R	R	R	R

Test Methods: The data presented in this chart is a compilation of testing by Pall Corporation with certain chemicals, manufacturer's data, or compatibility recommendations from the Compass Corrosion Guide by Kenneth M. Pruett. This data is intended to provide expected results when filtration devices are exposed to chemicals under static conditions for 48 hours at 25 °C (77 °F), unless otherwise noted. Membrane integrity for syringe filters was tested by bubble point.

This chart is intended only as a guide. Accuracy cannot be guaranteed. Users should verify chemical compatibility with a specific filter under actual use conditions. Because chemical compatibility is affected by many variables (including temperature, pressure, concentration, and purity), various chemical combinations prevent complete accuracy.

Caution: Alcohol residues that are allowed to dry on a filter may cause stress cracks. Pall Corporation recommends that filters used in alcohol processing should remain alcohol wet or should be flushed with copious quantities of water to remove residuals

prior to drying and subsequent reuse.

R = Resistant: No significant change was observed in flow rate or bubble point of the membrane. No visible indication of chemical attack was detected.

N = Not Resistant: The membrane or housing is basically unstable and is not recommended for use.

L = Limited Resistance: Moderate changes in physical properties or dimensions of the membrane were observed. The filter may be suitable for short term, non-critical use. Hardware or housing may be suitable for short-term exposure at low pressures and ambient temperatures.

— = Insufficient Data: Information is not available. Trial testing is recommended.

Ordering Information

Syringe Filters

Acrodisc 4 mm							
Sample	Membrane	P/N (50/pk)	P/N (100/pk)	P/N (1000/pk)	P/N (50/pk)	P/N (250/pk)	P/N (1000/pk)
		Pore Size: 0.2 µm	Pore Size: 0.2 µm	Pore Size: 0.2 µm	Pore Size: 0.45 µm	Pore Size: 0.45 µm	Pore Size: 0.45 µm
Organic / Non Polar	PTFE (CR)	—	—	—	—	WAT200508	—
Acrodisc 13 mm							
		P/N (50/pk)	P/N (100/pk)	P/N (1000/pk)	P/N (50/pk)	P/N (100/pk)	P/N (1000/pk)
		Pore Size: 0.2 µm	Pore Size: 0.2 µm	Pore Size: 0.2 µm	Pore Size: 0.45 µm	Pore Size: 0.45 µm	Pore Size: 0.45 µm
Aqueous / Polar	Nylon	—	WAT200524	WAT200834	—	WAT200520	WAT200832
	PVDF (LC)	—	WAT200806	—	—	WAT200512	WAT200827
	wwPTFE	—	186009314	186009331	—	186009315	186009319
	wwPTFE GF	—	—	—	—	—	—
	MS wwPTFE	186009243	—	—	—	—	—
Organic / Non Polar	PTFE (CR)	—	WAT200506	WAT200823	—	WAT200502	WAT200821
Ion Chromatography	PES (IC)	—	—	WAT200844	—	—	—
Acrodisc 13 mm Minispikes							
		P/N (50/pk)	P/N (100/pk)	P/N (1000/pk)	P/N (50/pk)	P/N (100/pk)	P/N (1000/pk)
		Pore Size: 0.2 µm	Pore Size: 0.2 µm	Pore Size: 0.2 µm	Pore Size: 0.45 µm	Pore Size: 0.45 µm	Pore Size: 0.45 µm
Aqueous / Polar	Nylon	—	WAT200562	WAT200835	—	WAT200564	WAT200836
	PVDF (LC)	—	WAT200804	WAT200838	—	WAT200560	WAT200828
Organic / Non Polar	PTFE (CR)	—	WAT200556	WAT200824	—	WAT200558	WAT200825
Ion Chromatography	PES (IC)	—	WAT200810	—	—	WAT200812	—
Acrodisc 25 mm							
		P/N (50/pk)	P/N (100/pk)	P/N (1000/pk)	P/N (50/pk)	P/N 100/pk)	P/N (1000/pk)
		Pore Size: 0.2 µm	Pore Size: 0.2 µm	Pore Size: 0.2 µm	Pore Size: 0.45 µm	Pore Size: 0.45 µm	Pore Size: 0.45 µm
Aqueous / Polar	Nylon	WAT200522	—	WAT200833	WAT200518	—	WAT200831
	Nylon GF*	—	—	—	WAT200800	—	WAT200846
	PVDF (LC)	WAT200808	—	WAT200839	WAT200510	—	WAT200826
	wwPTFE	186009327	—	—	186009326	—	186009323
	wwPTFE GF*	—	—	—	186009329	—	186009328
	MS wwPTFE	186009244	—	—	—	—	—
Organic / Non Polar	PTFE (CR)	WAT200504	—	WAT200822	WAT200500	—	WAT200820
Ion Chromatography	PES (IC)	—	—	—	—	—	WAT200843
Acrodisc 25 mm							
		P/N (50/pk)	P/N (1000/pk)				
		Pore Size: 1 µm	Pore Size: 1 µm				
Aqueous / Polar	Glass Filter	WAT200818	WAT200840				

Also available are 20–45 µm polypropylene filters in 96-well plates, 1.5–1.7 mL per well; 54 per pack, p/n: [186002799](#)

*wwPTFE GF and Nylon GF are glass fiber prefilters in combination with wwPTFE and Nylon filters for precipitate laden samples.

SOLVENT FILTRATION APPARATUS

The 300 mL capacity 47 mm Glass Filter Funnel and 1 L capacity 47 mm Glass Funnel/Support Assembly are ideal for vacuum filtration of liquids and degassing of HPLC solvent and mobile phases. The 100% borosilicate glass construction assures resistance to even the most aggressive solvents.

Ordering Information

Solvent Filtration Apparatus

Description	P/N
All Glass Filter Holder 47 mm, complete	WAT200543
Funnel, 300 mL	WAT200545
Glass Base, tabulated cap	WAT200546
Ground Joint Flask	WAT200547
Swinney Holder	WAT200566
Vacuum Pump 110 V, 60 Hz	725000417
Vacuum Pump 220 V, 50 Hz	725000604

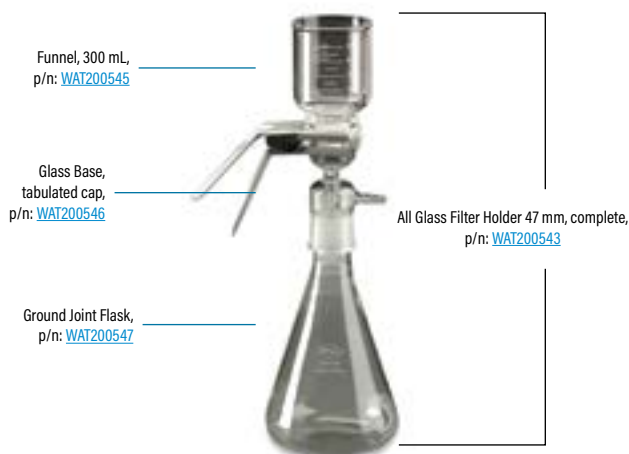

Syringe Filters

Acrodisc 47 mm							
Sample	Membrane	P/N (50/pk)	P/N (100/pk)	P/N (1000/pk)	P/N (50/pk)	P/N (100/pk)	P/N (1000/pk)
		Pore Size: 0.2 µm	Pore Size: 0.2 µm	Pore Size: 0.2 µm	Pore Size: 0.45 µm	Pore Size: 0.45 µm	Pore Size: 0.45 µm
Aqueous / Polar	Nylon	—	WAT200533	—	—	WAT200532	—
	PVDF (LC)	—	WAT200531	—	—	—	—
	wwPTFE	186009330	—	186009324	186009316	—	—
Organic / Non Polar	PTFE (CR)	—	WAT200535	—	—	WAT200534	—
Ion Chromatography	PES (IC)	—	WAT200539	—	—	WAT200538	—

Acrodisc 13 mm							
	Membrane	P/N (50/pk)	P/N (100/pk)	P/N (1000/pk)	P/N (50/pk)	P/N (100/pk)	P/N (1000/pk)
		Pore Size: 0.2 µm	Pore Size: 0.2 µm	Pore Size: 0.2 µm	Pore Size: 0.45 µm	Pore Size: 0.45 µm	Pore Size: 0.45 µm
Organic / Non Polar	PTFE (CR)	—	—	—	—	WAT200536	—
Ion Chromatography	PES (IC)	—	—	—	—	WAT200540	—

FLEXIBLE AUTOMATION FOR THE CONNECTED LABORATORY

The Andrew+ robot and OneLab software is your modern, liquid-handling automation platform that is easy to set up, without the need for extensive programming or engineering experience.

Benefits of Andrew+ Pipetting Robot Include:

- **Reproducibility:** Automated pipetting minimizes error
- **Productivity:** Time freed up for higher level tasks. User choice of any combination of single/multichannel pipetting increases flexibility
- **Promoting Health:** Reduced repetitive movement and exposure to hazardous materials

ONE ROBOT—MANY APPLICATIONS



Single/Multichannel Pipetting	Flexible Working Deck	Small Footprint	OneLab Communication
<ul style="list-style-type: none"> ■ Best-in-Class Andrew Alliance electronic pipettes ■ Manufactured by Sartorius ■ Bluetooth communication with Andrew+ 	<ul style="list-style-type: none"> ■ Wide range of consumables ■ Supported by an ever expanding range of domino accessories 	<ul style="list-style-type: none"> ■ Compact multichannel pipetting robot ■ Doesn't require dedicated space ■ Easily located under a hood 	<ul style="list-style-type: none"> ■ Intuitive design of pipetting protocols ■ Execute OneLab protocols on Andrew+ through a WiFi/Ethernet connection ■ Securely share protocols with other lab members

The Andrew+ robot executes OneLab protocols, enabling fully automated, traceable, and highly repeatable pipetting, in addition to an expanding range of more complex protocols.

General Liquid Handling

- Serial Dilution – OneLab calculates required volumes and concentrations, taking full account of sample viscosity and dilution of inhibitors/substances in the samples that can interfere with downstream analytics.
- Standard Curve – Create a series of standards of increasing concentration in order to produce a calibration curve.
- Concentration Normalization – OneLab, through its Normalization Wizard, and Andrew+ automates the production of concentration normalized volumes, typically saving time required for what is often a highly laborious exercise.
- Microplate Reformatting – Handle a wide range of aliquoting operations between different types of microplate, microtube, vials, and racked HPLC tubes.

General Sample Preparation

- Dilute and Shoot – Samples are diluted with an internal standard to be directly injected onto an LC-MS system.
- Protein Precipitation (PPT) – Methods to concentrate proteins and purify them from various matrices.
- Phospholipid Removal – One of the major causes of ion suppression in bio-analysis is phospholipids.
- Solid-Phase Extraction – With the Vacuum+ you can automate micro and macro elution SPE plates. Addition of the Ika pump allows for vacuum control.

Complex Workflows

There are a wide range of protocols available on onelab.andrewalliance.com for automation of more complex workflows that require liquid handling, SPE, heating/shaking, magnetic bead based separation and more. Protocol categories include:

- Bioanalysis
- Biopharmaceutical
- Biomedical Research
- Cell Biology
- Diagnostics
- Drug Discovery
- Food testing

Request a Quote

Fill out our purchase inquiry form and receive a quote from an automation specialist today.

 For more information please visit: waters.com/andrewalliance



APPLICATION AREA: Automated liquid handling in all the labs where transferring methods between devices

"Excellent product as easy to design and executive protocols. Minimizes human intervention and ensures compliance."

REVIEWER: Ningappa H M

ORGANIZATION: AIC ENTERPRICES PVT. LTD

SMARTER, REPRODUCIBLE AND TRACEABLE PIPETTING

Electronic pipettes made smart through connectivity. Using step-by-step visual guidance, Pipette+ allows you to execute protocols designed in OneLab with connected, electronic pipettes to minimize execution errors and provide full experimental traceability.

Benefits of Pipette+ Guided Pipetting System Include:

- **Reproducibility:** Volume and pipette parameters are set automatically, correct pipette selection confirmed, and usage monitored; all contributing to minimizing error
- **Productivity:** Researchers spend less time repeating experiments
- **Traceability:** Ensures systematic and accurate identification of sources of pipetting error

Pipette 
easy pipetting



OneLab

- Intuitive graphical design of executable pipetting protocols.
- Step-by-step guidance of experiment protocols, ensuring repeatability.
- Facilitates sharing protocols with other researchers.



Pipette+ Stand

- Intelligent, computerized stand communicating with OneLab through Wifi/Ethernet and with pipettes by Bluetooth.
- Identifies and confirms correct pipette selection.
- Pipette parameters are set by OneLab. Correct use assured by real-time monitoring of pipette identity, performance and possible errors.
- Charges pipettes.



Andrew Alliance Pipettes

- Range of single channel (0.2 μ L to 10 mL) and 8- and 12-channel electronic pipettes provides maximum flexibility of use.
- Pipette parameters are set automatically by OneLab while user conducts experiment.
- Lightest electronic pipettes on the market + electronic tip ejection = best-in-class ergonomics.

Ordering Information

Pipettes

Description	Compatibility	P/N
Single channel AA Pipette, 0.2-10 µL	Andrew+, Pipette+	186009769
Single channel AA Pipette, 5-120 µL	Andrew+, Pipette+	186009765
Single channel Pipette, 10-300 µL	Andrew+, Pipette+	186009606
Single channel AA Pipette, 50-1000 µL	Andrew+, Pipette+	186009766
Single channel Pipette, 100-5000 µL	Andrew+, Pipette+	186009608
Single channel AA Pipette, 500-10000 µL	Andrew+, Pipette+	186009767
8-channel AA Pipette, 0.2-10 µL	Andrew+, Pipette+	186009768
8-Channel AA Pipette, 5-120 µL	Andrew+, Pipette+	186009605
8-Channel AA Pipette, 10-300 µL	Andrew+, Pipette+	186009607
8-Channel AA Pipette, 5-1200 µL	Andrew+, Pipette+	186009615
12-channel AA pipette, 0.2-10 µL	Pipette+	186010102
12-channel AA Pipette, 5-120 µL	Pipette+	186010103
12-channel AA Pipette, 10-300 µL	Pipette+	186010104
12-channel AA Pipette, 50-1200 µL	Pipette+	186010105

Request a Quote

Fill out our purchase inquiry form and receive a quote from an automation specialist today.

 For more information please visit: waters.com/andrewalliance



APPLICATION AREA: Power generation

"Excellent product with good value for money. Easy to use and ease of operation for water treatment plant operators."

REVIEWER: Garimesh Sharma

ORGANIZATION: Sidhee Cement Limited

CONNECTED DEVICES + TOOLS

Discover the rapidly evolving ecosystem of connected devices and tools for use with Andrew+, Pipette+ and OneLab to support a wide range of laboratory workflows.

 For more information please visit: andrewalliance.com/additional-connected-devices

Ordering Information

Connected Devices + Tools

Description	P/N*
96-PCR Plate Magnet+	176004850
50 mL Tube Magnet+	176004851
Deepwell Magnet+	176004854
Microplate Peltier+	176004852
96-PCR Plate Peltier+	176004584
Tube Shaker+	176004853
Microplate Shaker+	176004577
Microplate Vacuum+	176004579
Microplate Gripper	186009776
Tube Gripper	186010179

*Includes Device+ license to connect with OneLab

UNIQUE SOFTWARE FOR THE DESIGN AND EXECUTION OF LAB PROTOCOLS

OneLab is a browser-based software environment enabling researchers to design, share, and execute protocols, through an intuitive graphical interface. Use drag-and-drop to design new protocols on any PC or tablet from anywhere, whether you are in the lab or at your desk. You can also start with existing protocols, by selecting from the comprehensive OneLab library, enabling you to get up and running even faster. Executed step-by-step experiments with Pipette+ for manual, guided pipetting, or with Andrew+ and connected devices for a fully automated, walk-away solution.

Benefits of OneLab Laboratory Software Include:

- **Traceability:** Trace all steps from protocol design to experiment execution and report generation
- **Security and Data Privacy:** Ensures security of lab protocols through secure user identification and access control
- **Laboratory Management:** Seamless collaboration and training and the elimination of tedious manual procedures

APPLICATION AREA: Automated liquid handling in all the labs where transferring methods between devices

OneLab 
design & execute



Request a Quote

Fill out our purchase inquiry form and receive a quote from an automation specialist today.

 For more information please visit: waters.com/andrewalliance



"Good results for every day use in lab. Allowing full traceability of biological experiments with browser-based software environment, graphically design own pipetting protocols with short term executed results and option for monitoring ongoing experiments, it's high quality user friendly interface with modern design, great sampling and good return of investment."

REVIEWER: Bernard Zjakic

ORGANIZATION: Kajak kanu klub Una Bihać

Sample Processing Devices and Accessories



SEMI-AUTOMATED SOLID PHASE EXTRACTION PROCESSING

The Otto™ SPEcialist Positive Pressure Manifold is designed to further improve method robustness and sample reproducibility for solid-phase extraction. Controlled by an interfaced tablet with easy-to-use software, the semi-automated Otto SPEcialist simplifies method development and transfer, positive pressure optimization, and real-time manipulation of pressure profiles while removing the variability of manual extraction systems. The Otto SPEcialist is compatible with μ Elution and macro elution plates; and 1 cc, 3 cc, and 6 cc cartridges.



Compatible SPE Devices:

- (1) μ Elution™ Plate
- (1) Macro Elution Plate
- (24) 1 cc Flanged/Flangeless Cartridges
- (96) 1 cc Flangeless Cartridges
- (24) 3 cc Flanged/Flangeless Cartridges
- (18) 6 cc Flanged/Flangeless Cartridges

Ordering Information

Description	Contents	P/N
Otto SPEcialist Positive Pressure Manifold	Otto SPEcialist Positive Pressure Manifold	72500682
Otto Elution Plate Startup Kit	186009712 μ Elution Spacer 186009713 μ Elution Platform 186009714 Drainless Waste Reservoir	176004605
Otto 1 cc Cartridge for 13 mm Collection Tubes Startup Kit	186009716 1 cc Top Rack 186009715 13 mm Tube Collection Rack 186009708 13 mm Tube Spacer for 75 mm 186009714 Drainless Waste Reservoir	176004606
Otto 1 cc Flangeless Cartridge for 96-Well Collection Plate Startup Kit	186009717 Flangeless 1 cc Top Rack 186009713 μ Elution Platform 186009718 2 mL Collection Plate Position 186009714 Drainless Waste Reservoir	176004607
Otto 3 cc Cartridge for 13 mm Collection Tubes Startup Kit	186009719 3 cc Top Rack 186009715 13 mm Tube Collection Rack 186009708 13 mm Tube Spacer for 75 mm 186009714 Drainless Waste Reservoir	176004608
Otto 3 cc Cartridge for 16 mm Collection Tubes Startup Kit	186009719 3 cc Top Rack 186009720 16 mm Tube Collection Rack for 3 cc 186009721 3 cc 16 mm Tube Spacer for 75 mm 186009714 Drainless Waste Reservoir	176004609
Otto 6 cc Cartridge for 13 mm Collection Tubes Startup Kit	186009722 6 cc Top Rack 186009723 13 mm Tube Collection Rack for 6 cc 186009724 6 cc 13 mm Tube Spacer for 75 mm 186009714 Drainless Waste Reservoir	176004610
Otto 6 cc Cartridge for 16 mm Collection Tubes Startup Kit	186009722 6 cc Top Rack 186009725 16 mm Tube Collection Rack for 6 cc 186009726 6 cc 16 mm Tube Spacer for 75 mm 186009714 Drainless Waste Reservoir	176004611
Waste Reservoir with Drain	Waste Reservoir with Drain	186009727

Fit-for-Purpose Sample Vials for LC and LC-MS

Reduce risks and costs while increasing data quality by choosing the most reliable Waters vial for your LC analysis.



Vial Type	Routine Analysis		Advanced Analysis	
	High Value Glass and Polypropylene	LCGC Certified	TruView™ pH Control LCMS Certified	QuanRecovery™ with MaxPeak™ HPS
Applications	Legacy methods and higher analyte concentrations. Clear and polypropylene vials where glass surface is not applicable.	High-throughput QC analysis in the regulated environment, for compounds in aqueous. No lot-to-lot variations from glass manufacturing, packaging, residues, or waste materials.	LC-MS and routine QC analysis and quantification for sample concentrations below 1 ng/mL. Ideal for pH sensitive assays. Reduced adsorption of polar analytes. For pH sensitive compounds and analytes, reduced adsorption of polar bases with high lot-to-lot consistency.	Qualification and quantification of low abundance species with complex structures (aesthetics and hydrophobic compounds).
Benefits	High value, low cost. Choose cap and septum separately.			High recovery and reproducibility after short or long term storage of low abundance species with complex structures.
Features		Vials are assembled and tested for contaminants with a standard LPLC/LC separation at 100 nm resolution. Performance.	Chemically enhanced glass surface to reduce leaching of Na and other metal ions into solutions with high lot-to-lot consistency (0.3 ppm) and reduced adsorption effects.	Coating the vial's recast polypropylene surface to reduce active sites, non-specific binding, and hydrophobic interaction.
Certification Tests	<ul style="list-style-type: none"> Dimensionally tested Lot traceability 	<ul style="list-style-type: none"> Dimensional checks USP/CEP certified assembly Dimensionally tested 	<ul style="list-style-type: none"> pH certified Low adsorption certified MS certified cap and septa USP/CEP certified assembly 	<ul style="list-style-type: none"> Protein recovery QC tested Dimensionally tested
Shapes				
Surfaces	USP Type 1, 23 Glass (amber) USP Type 1, 23 Glass (clear) Polypropylene	USP Type 1, 23 Glass (amber) USP Type 1, 23 Glass (clear)	USP Type 1, 23 Glass, Low Na (amber) USP Type 1, 23 Glass, Low Na (clear)	MaxPeak HPS (High Performance Surface) Polypropylene

Visit us online to view our infographic waters.com/vials

LCGC Certified

TruView™ pH Control
LCMS Certified

QuanRecovery™
with MaxPeak™ HPS

Learn more by visiting waters.com/vialselector