

N418LA User Manual



Contents

Change History	4
How to use this Manual	4
Introduction	5
Warranties and Liabilities	6
Safety Notices	7
Symbols	7
Safety Notice to Users	7
Declaration of Conformity	8
Environmental Declaration	9
Technical Specification	10
Environment	10
Generator Outlets	10
Electrical Requirements	10
General	10
Unpacking	11
Installation	12
Generator Environment	12
Removal of Transit Brackets	13
Unit Controls	14
Rear Connections	14
Fittings Kit	15
Drain Connection	15
Electrical Connection	16
Initial Purge Run	18
Connecting to the Application	18
Tubing Lengths	19
Warranty Entitlement	20
Normal Operation	21
PLC Display	21

Sleep Mode	22
Screen messages	23
On Demand Gas	24
Unusual Operation	24
Pressure/Flow Adjustment	24
System Drain	24
Service Requirements	25
Service Schedule	25
Service Indication	25
Stage 1	25
Stage 2	25
Service Indication Reset	26
Service Plans	26
Cleaning	26
High Duty Indication	27
High Duty Indication Reset	27
Trouble Shooting	28

Change History

Rev	Comment	Name	Date
1	Added shake-proof washer to Transit Bracket	Liam Couttie	27/06/13
2	Fuse Information Added	Liam Couttie	26/09/13
3	Fittings Kit Update	Liam Couttie	04/02/16
4			
5			

How to use this Manual

This manual is intended for end users and has been written so that it can either be read as a step by step guide to installation and usage or as a reference document where you can skip to the relevant information.

Users of a hard copy version can refer to the contents page to find the relevant information. Users of the soft copy version can use the hyperlinks from the contents page as well as the hyperlinks between sections.

Please review each of the following sections carefully.

Thank you for selecting Peak Scientific to meet your Gas Generation needs, and should you require any further assistance or support please do not hesitate to contact Peak Scientific or Peak Partner from which you purchased your Generator.

Introduction

The N418LA has been developed to cater for systems which require a Nitrogen gas supply.

With the N418LA based on proven technology, it selectively removes oxygen, moisture and other gases to leave clean, dry, phthalate free Nitrogen. Internal air compressors make this unit independent from in-house air supplies and fitted castors allow the user to easily position the unit in the lab.

To ensure this Generator model meets our high expectations with regards to reliability and performance, we have tested this new model extensively at our manufacturing plant and with end users around the world to ensure reliability and longevity of the system.

Warranties and Liabilities

1. The Company warrants that it has title to the Goods.
2. Subject to the provisions of this clause the Company warrants that the Goods shall comply in all material respects with any specification referred to in the Order Confirmation (as the same may be amended) and shall, subject thereto, be free from defects in material and workmanship for the lesser of a period of twelve months from the date of delivery or thirteen months from the date of dispatch from the factory.
3. Save as provided in this clause and except where the Goods are sold to a person dealing as a consumer (within the meaning of the Unfair Contract Terms Act 1977) all warranties, conditions or other terms implied by statute or common law are hereby expressly excluded save to the extent they may not be lawfully excluded. When the Goods are sold to a consumer within the meaning of the Unfair Contract Terms Act 1977 their statutory rights are not affected by the provisions of this clause.
4. In the event of the Customer making a claim in respect of any defect in terms of clause 2 hereof the Customer must.
 1. Reasonably satisfy the Company that the Goods have been properly installed, commissioned, stored, serviced and used and without prejudice to the generality of the foregoing that any defect is not the direct or indirect result of lack of repair and/or servicing, incorrect repair and/or servicing, use of wrong materials and/or incorrect spare parts
 2. Allow the company to inspect the Goods and/or any installation and any relevant packaging as and when reasonably required by the Company.
5. Subject to the Company being notified of any defect as is referred to in sub-clause 2 hereof within a reasonable time of it becoming apparent and subject always to the terms of sub-clause 4 hereof, the Company shall, in its option, replace or repair the defective Goods or refund a proportionate part of the Price. The Company shall have no further liability to the Customer (save as mentioned in sub-clause 6 hereof).
6. The Company shall be liable to indemnify the Customer in respect of any claim for death or personal injury to any person in so far as such is attributable to the negligence or breach of duty of the Company or any failure by the Company to comply with the provisions of sub-clause 2 hereof.
7. Save as provided in sub-clause 2 hereof the Company shall not be liable in respect of any claim by the Customer for costs, damages, loss or expenses (whether direct, indirect, consequential or otherwise) or indemnity in any respect howsoever arising including, but not by way of limitation, liability arising in negligence (other than pursuant to clause 6 above) that may be suffered by the Customer or any third party.

Safety Notices

Symbols

This manual uses the following symbols to highlight specific areas important to the safe and proper use of the Generator:



	A WARNING notice denotes a hazard. It calls attention to an operating procedure, process or similar, which if not correctly performed or adhered to, could cause personal injury or in the worst case death. Do not proceed beyond a WARNING notice until the indicated conditions are fully understood or met.
	A CAUTION notice denotes a hazard. It calls attention to an operating procedure, process or similar, which if not correctly performed or adhered to, could cause damage to the Generator or the Application. Do not proceed beyond a CAUTION notice until the indicated conditions are fully understood or met.
	Caution, risk of electric shock. Ensure power to the Generator has been removed before proceeding.

Table 1 - Safety Symbols

Safety Notice to Users



These instructions must be read thoroughly and understood before installation and operation of your Peak Generator. Use of the Generator in a manner not specified by Peak Scientific MAY impair the SAFETY provided by the equipment.



When handling, operating or carrying out any maintenance, personnel must employ safe engineering practices and observe all relevant local health and safety requirements and regulations. The attention of UK users is drawn to the Health and Safety at Work Act 1974, and the Institute of Electrical Engineers regulations.

Declaration of Conformity

We **Peak Scientific Instruments Ltd.**

of **Fountain Crescent, Inchinnan. Renfrewshire PA4 9RE**
declare that:

Equipment **Nitrogen Gas Generator**

Model **N418LA**

To which this declaration relates, is in conformity with the applicable EC Directives, harmonized standards, and other normative requirements.

- **Low Voltage Directive 2006/95/EC**
EN 61010-1: 2001
Safety Requirements for Electrical Equipment for Measurement, Control and Laboratory Use.

CAN/CSA-C22.2 No.61010-1-04
Safety requirements for Electrical Equipment for Measurement, Control and Laboratory use, Part 1: General requirement.
- **Electromagnetic Compatibility Directive 2004/108/EC**
EN 61326-1: 2006
Electrical Equipment for Measurement, Control and Laboratory Use – EMC Requirements.
- **FCC 47 CFR Part 15 class B**
Unintentional radiators; Conducted and Radiated emissions limits.

All evaluation, testing and certification issued by:

Nemko Canada Inc.
303 River Road
Ottawa
Ontario
Canada
K1V 1H2

TUV Product Service Ltd.
Octagon House, Concorde Way
Segenworth North, Fareham
Hampshire
England
PO15 5RL

Signed By:



Name: **Chris Pugh**

Position: **Engineering Director**

Done at: **Peak Scientific Instruments Ltd, Inchinnan, Scotland.**

Date: **30th of January 2012**



Environmental Declaration

We Peak Scientific Instruments Ltd.

of Fountain Crescent, Inchinnan. Renfrewshire PA4 9RE
declare that:

Equipment Nitrogen Gas Generator

Model N418LA

Is fully compliant with the following Directives:

2002/96/EC WEEE (Waste of Electrical and Electronic Equipment)

2002/95/EC RoHS (Restriction of Hazardous Substances)

Peak Scientific Instruments Ltd fully complies with its obligations towards the European WEEE (Waste of Electrical and Electronic Equipment) Directive 2002/96/EC. These obligations are being met within the B2B compliance group.

Peak Scientific Instruments Ltd has developed all reasonable 'due diligence' controls to ensure that our products comply with the principles and requirements of the European RoHS (Restriction of Hazardous Substances) Directive 2002/95/EC. Similar directives in the United States and China, for example, have also been captured within this program.

Where a specific certificate of compliance is required, this can be requested, on a product serial number basis, directly from Peak Scientific Instruments Ltd, by contacting us through our website on www.peakscientific.com

Signed By:



Name: Chris Pugh

Position: Engineering Director

Done at: Peak Scientific Instruments Ltd, Inchinnan, Scotland.

Date: 30th January 2012



Technical Specification

Environment

Minimum operating ambient temperature	5°C (41°F)
Maximum operating ambient temperature	25°C (77°F)
Maximum relative humidity	70%
Maximum altitude	2000 meters

*NOTE - When taken out of storage the Generator should be allowed to acclimatize at room temperature for a minimum of 3 hours before operation.

Generator Outlets

Maximum Flow	18 L/min (0.64 cfm)
Maximum Pressure	6.90 bar (100 psi)
Particles	<0.01µm
Phthalates	NONE
Suspended liquids	NONE
Gas outlets	1 x ¼" BSPP
Pressure gauges	1
Start-up Time	30 min

Electrical Requirements

Voltage	230 VAC ± 10%
Frequency	50/60 Hz
Current	3.6 Amps
Input connection	C19 Plug
Fuse	10 Amps
Power cord (Supplied)	C19 socket to local connection (13A minimum)
Pollution degree	2
Installation category	II

General

Dimensions in cm (inches) W x D x H	40 x 70 x x71 (15.7 x 27.5 x 28)
Weight	60 kg (132 lb)
Shipping weight	85 kg (187 lb)
Noise level	54 dBA @1m

Unpacking

Although Peak Scientific takes every precaution with safe transit and packaging, it is advisable to fully inspect the unit for any sign of transit damage.

Check 'SHOCKWATCH' label for signs of rough handling prior to un-packing –



Any damage should be reported immediately to the carrier and Peak Scientific or the Peak Partner from where the unit was purchased.

Follow the unpacking instructions posted on the side of the crate. It will require two people to remove the unit from the shipping crate and to manoeuvre the Generator onto the floor.

Please save the product packaging for storage or future shipment of the Generator.

Note: Included with the Generator is a "Fittings Kit" containing mains power leads for UK, EU and US also all the required fittings. Be careful not to discard these with the packaging.

Installation

Generator Environment



The Generator is designed for indoor use only. It should be installed adjacent to the application it is supplying. If this is not convenient then the unit can be sited elsewhere, however, consideration should be made of the lengths of pipe runs as pressure drops can result from extended runs of pipe. Please see the [Tubing lengths](#) section for further details.



Performance of the Generator (like all sophisticated equipment) is affected by ambient conditions. Note should also be taken to the proximity of Air Conditioning outlets. These can sometimes give rise to “pockets” of air with high relative humidity. Operation of the unit within such a pocket could adversely affect its performance. Consideration should also be given to the air flow around the unit. It is recommended that an air gap of 75mm (3”) should be maintained down both sides, at the rear and across the top of the unit. Please refer to the drawing below for the general dimensions of the unit.

Maximum Ambient Conditions: 25°C (dry bulb) 70%RH (Max) Non-Condensing

General Dimensions

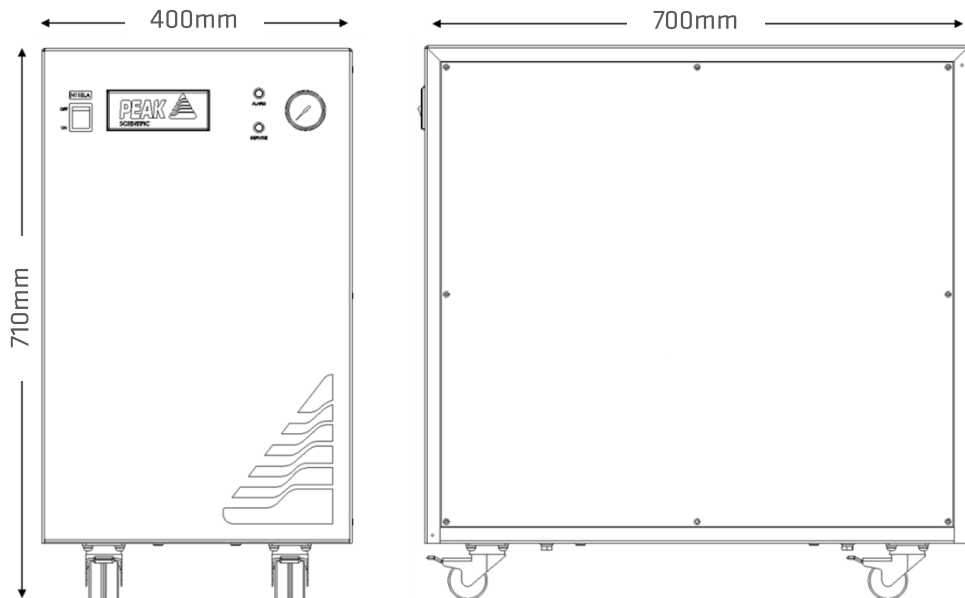

The Generator must always be placed on a level surface. Failure to do so will affect the performance of the Generator.

Removal of Transit Brackets



The transit brackets must be removed prior to switching the unit on. Failure to do so will result in damage to the equipment. This will void the warranty on the Generator and will result in a chargeable repair.

1. Using the 2.5mm hex key from the Fittings Kit, remove the side cover from the cabinet ensuring that earth cable is disconnected.
2. Remove the four 'Thumb' screws and shake-proof washers from the underside of the compressor compartment.

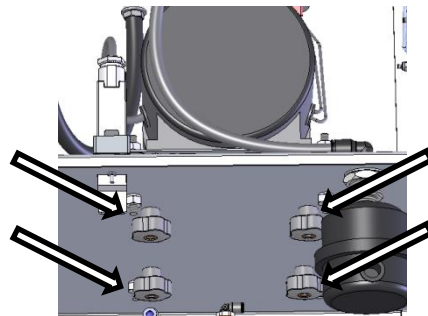

Figure 1: Remove the four 'thumb' screws

3. Lift the transit bracket up until the locating pin and threaded stud are clear of the compressor mounting plate and compartment floor, remove fully and repeat for the other transit bracket.

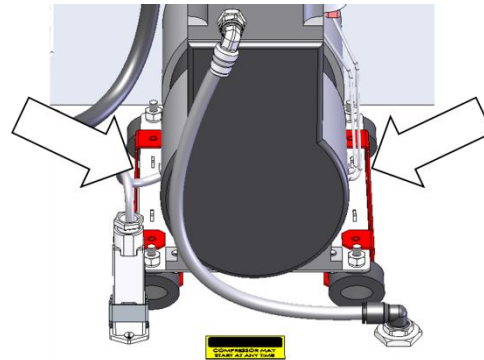
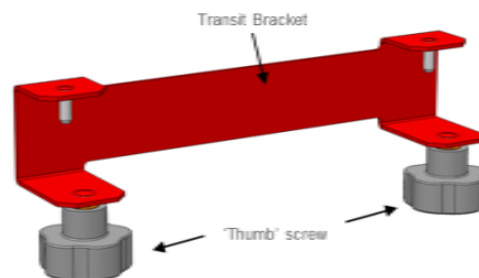

Figure 2: Remove the two transit brackets

4. Retain the transit brackets, shake-proof washers and 'thumb' screws, as these must be refitted if the Generator is to be transported again.



Note. Do not re-fit door panels in preparation for Voltage Check

Unit Controls

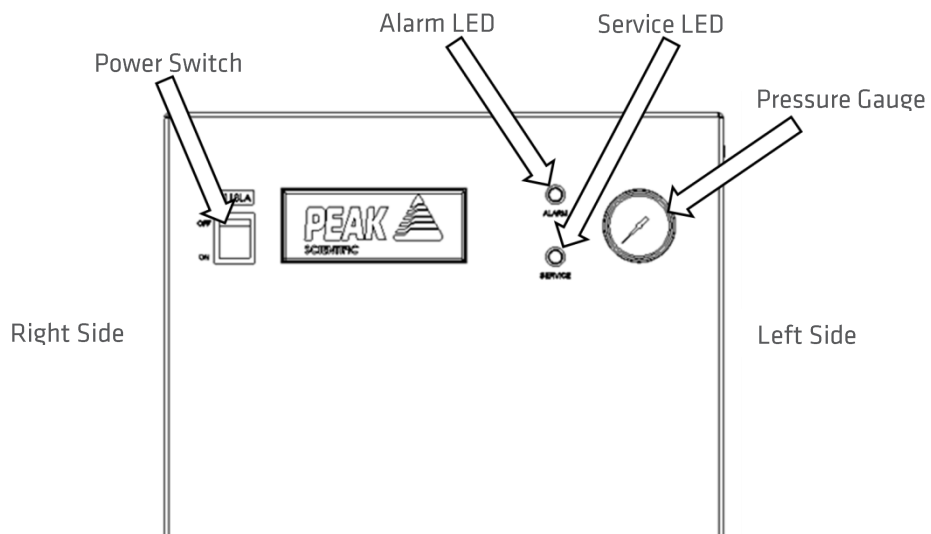

Figure 2: Unit Controls

Rear Connections

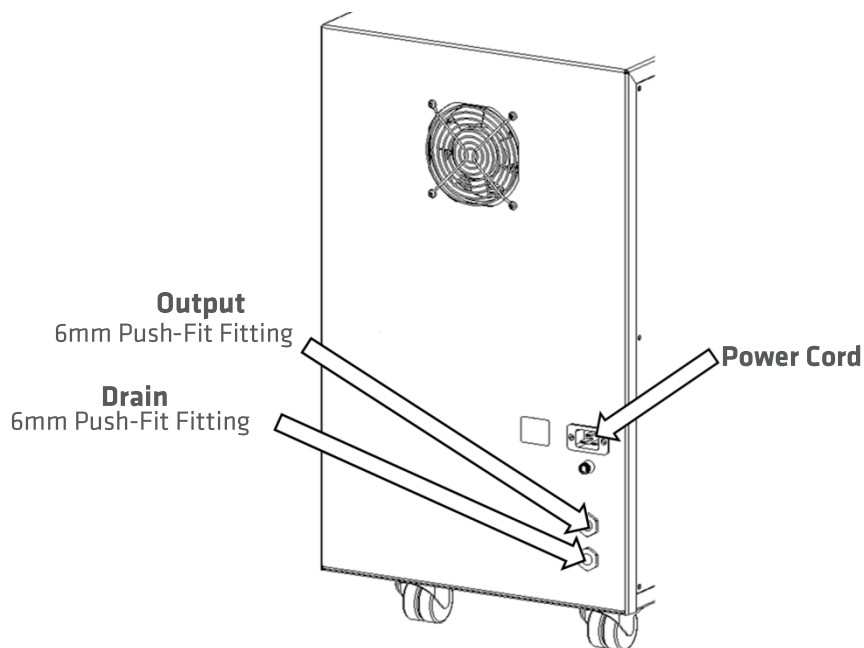

Figure 3: Rear Connections

Note: Do not fit the 6mm fitting to the Output until after the initial purge run.

Fittings Kit

Supplied in the Fittings Kit are all the fittings required to connect the N418LA Generator to the application. The contents of the Fittings Kit are as follows:

1.	2.5mm Hex Key	Q 1
2.	6mm Push Fit Fitting	Q 3
3.	¼" Compression Fitting	x 2
4.	6mm Teflon Tubing (white)	Q 3m
5.	¼" Teflon	x 3m
6.	6mm High Temp Tubing (silver)	x 2m
7.	¼" Tee Compression Fitting	x 1
8.	Flow Control Silencer	x 2
9.	C19 Mains Cable (UK)	Q 1
10.	C19 Mains Cable (Euro)	Q 1
11.	C19 Mains Cable (US)	Q 1
12.	Installation Guide - N418LA	x 1

All of the Generator output ports are located on the output panel at the rear of the Generator.

Drain Connection

Fit the 6mm Push-Fit fitting (item 2 from fittings kit) to the drain port located on the output panel. Tighten using a 16mm or 5/8" spanner. Use the 6mm High Temp tubing (item 3 from fittings kit), to connect this to a suitable drain connection or container. It should be noted that the Generator can expel a considerable amount of water from this (dependant on ambient humidity).



If a container is used it should be emptied at regular intervals. The container must NOT have an air tight seal as water and air are expelled at pressure.

Electrical Connection

Connect the Generator to a 230 volt single-phase supply using the power cord provided. If the appropriate power cord is not supplied; a new plug, rated to at least 12 amps, can be fitted by a qualified electrician.



This unit is classified as SAFETY CLASS 1. THIS UNIT MUST BE EARTHED. Before connecting the unit to the mains supply, please check the information on the serial plate. The mains supply must be of the stated AC voltage and frequency.

EARTH/GROUND (E):-	Green & Yellow	or	Green
LIVE (L):-	Brown	or	Black
Neutral (N):-	Blue	or	White

Our electrical requirements are 230VAC nominal +/- 10%. This means that the Generator can accommodate transients between 207VAC and 253VAC. However, running continuously at voltages less than 220V is not recommended and extended periods at these extremes can have a detrimental effect on the operation and life of the Generator.

To ensure that the correct voltage is being supplied to the Generator, the N418LA comes equipped with an inbuilt voltmeter.

The voltmeter should be checked prior to the initial purge of the system. To do this, with the doors remaining off and with the Generator still connected to the 230 volt single-phase supply, the unit should be powered ON using the power switch (identified by "I").



Do not touch anything inside the Generator whilst the side panels are removed and the mains power is connected to the unit

When the Generator is switched on, the input voltage will be displayed on the voltmeter. If this reading is 219V or less, then we would highly recommend fitting a transformer. This can be ordered directly from Peak Scientific with the order number being as below.

Product Description	Part Number
Dual Tap Transformer 200V – 230V	06-3200

Table 2: Additional Transformer

On completing the voltage check, the Generator should be powered OFF using the switch on the front panel, the power cord removed from the rear of the generator and the door panels refitted.



Ensure the Earth wires are reconnected to the side covers when refitting.

Initial Purge Run



Before the Generator is connected to the application, the Generator should be operated in isolation (i.e. not connected to the application) for thirty minutes. This is to ensure any impurities present are purged from the system. Failure to do this may harm the application.

Connect the Generator to the mains and switch on.

Pressure will start to build in the internal storage tanks which can be monitored by watching the output pressure gauge on the front panel. This will climb to the factory set pressure as noted in the [specifications](#).

Once this pressure is reached, the compressor will continue to run until the internal tank upper pressure limit is reached and the compressor has run for a period of at least two and a half minutes.

The compressor will then rest until the internal tank lower pressure limits is reached. Once this limit is reached the compressor will switch back on again. This compressor cycling is normal and will continue throughout the operation of the Generator.

When the system has been operated for a period of 30 minutes, all the internal pipe-work and storage tanks will have been purged with Nitrogen.

The Generator is now purged and the tubes can be connected at the rear of the unit.

Connecting to the Application

Once the initial purge run of 30 minutes has completed the Generator is now ready to be connected to the application.



The pressure in the internal storage tanks must be allowed to dissipate before connecting the Generator to the Mass Spectrometer

Depending on the size of the applications inlet, attach either the 6mm Push-Fit or ¼" Compression fitting to the outlet of the Generator. Using the appropriate sized Teflon tubing supplied, connect the outlet of the Generator to the inlet on the application.

If you require more tubing than is supplied please refer to the [Tubing Lengths](#) section.



Once the tubing is connected to the application, please ensure that it is thoroughly checked for leaks. Even the slightest leak in the gas supply between the Generator and the application can lead to a reduction in efficiency.

Tubing Lengths



The diameter of the tubing which will be connected to the gas outlet is important and is determined by the length of tubing required. Failure to follow these recommendations could lead to pressure between generator and application.

- | | |
|-------------------|---|
| < 10 meters: | Use 6/4 (6mm O/D, 4mm I/D) P.T.F.E. tubing. |
| > 10 - 40 meters: | Use 10/8 (10mm O/D, 8mm I/D). Tubing and fittings not supplied in the fittings kit. |
| > 40 metres: | Please contact Peak Scientific with the relevant distance and we will calculate the flow resistance and the tubing size required. |

A combination of 6/4 and 10/8 tubing may be used to ensure that there is no large diameter tubing within the lab (i.e. for the first 20 meters from the Generator use 10/8 and the final 10 meters to the application use 6/4 tubing). Keep the connections and bends to a minimum.

The imperial equivalents are: 6/4 = 1/4" O/D, 3/16" I/D.
10/8 = 3/8" O/D, 5/16" I/D.

IMPORTANT DOCUMENTS



Warranty Entitlement

To register your generator for your warranty entitlement, send the completed form to Peak Scientific by:

- Email warranty@peakscientific.com
- Online http://www.peakscientific.com/service-and-support/warranty_registration
- Phone +44 (0)141 530 4185
- Fax +44 (0)141 812 8200

PRODUCT WARRANTY REGISTRATION	
COMPANY:	CONTACT NAME:
ADDRESS:	
	EMAIL ADDRESS:
CITY/TOWN:	GENERATOR SERIAL NUMBER:
POSTCODE:	
COUNTRY:	MODEL TYPE:
TELEPHONE:	INSTALLATION DATE (DD/MM/YYYY):

Important Please Note:

You have 1 month to register your Peak Scientific product from the date of shipment.

If you wish to defer installation of your generator you must notify Peak Scientific within 1 month of the shipment date. This can be done by emailing warranty@peakscientific.com Once registered the warranty will be honoured for a period of 12 months after the installation date.

For any generators that remain unregistered the warranty will begin from date of shipment.

Thank you on behalf of Peak Scientific.

Normal Operation

The N418LA generator is designed specifically to minimize operator involvement. Given that the system is installed as described in earlier sections and is serviced in accordance with the following maintenance recommendations then it should simply be a matter of turning the generator on.

The generator will automatically produce the factory default flow and pressure.

PLC Display

During normal operation the PLC will display various messages. The default screens display firstly, the generator model number, software revision and indicate if SLEEP mode is 'Enabled' or 'Disabled'. The remaining default screens highlight run time parameters: 'Generator Total Run' and 'Compressor Total Run', both measured in days & hours. And lastly 'Compressor Service Due', this is measured in hours only.

'Generator Total Run' and 'Compressor Total Run': begins at 0 and counts up but only when the compressor runs. 'Comp Service Due': starts at 3750 counting down to 0, again only when the compressor runs.

If the compressor were to run continuously for 8 hours or more the 'High Duty' LED will be illuminated and a new default message appears on the screen, displaying 'High Duty Comp ran *hours continuously'.

The PLC limits the start/stop cycles of the compressor this allows the motor to run to its optimum ability.

(* High Duty Counter value)

Sleep Mode

The generator also includes an optional Sleep Mode function that will operate if the Instrument it is supplying goes into a standby or shutdown. The generator Sleep Mode is enabled as standard when the unit is despatched from the factory and can be disabled by moving a jumper on the PLC.

When enabled this function detects if the gas consumption rate falls below 2 l/min. If the consumption rate does fall below 2 l/min then it will drop the lower pressure set point from 110psi to 80psi. This allows the compressor to rest for longer periods of time, extending the life of the unit. Sleep mode is enabled as standard. Should you wish to disable the Sleep Mode, remove the jumper from terminal 9 and place in the adjacent terminal 11. Sleep mode can be re-enabled at any time by moving the jumper wire back to terminal 9.



Accessing the electrical panel should not be done without safely isolating the Generator first.

Sleep Mode Enabled
Connected to Terminal 9



Sleep Mode Enabled, jumper wire connected to terminal 9.

Screen messages

“Sleep Mode Enabled” will be displayed on the PLC display when Sleep Mode is Enabled.



When Sleep Mode is Disabled the screen will display “Sleep Mode Disabled”.



Sleep mode will be activated once the generator has detected low flow. The screen will then display “Sleep Mode Active”.



On Demand Gas

The Generator produces gas on demand. If the application is operating and requires a gas flow, the Generator will supply this to suit the requirements of the application. If the application requirement for gas stops, the Generator will also stop, once it has reached its upper set limit in the internal storage tanks. If the demand from the application starts again, the Generator will detect the demand for gas and will automatically start again to suit the demand.

Unusual Operation

If at any time the Generator begins to emit excessive noise or vibration, then it should be switched off and you should contact Peak Scientific or the Peak Partner from which the Generator has been purchased.

Pressure/Flow Adjustment

The system is configured in the factory to give standard Outlet Pressure and Flow Rate (see 'Technical Specification'). **These settings should never require adjustment during normal operation.** During service/fault diagnosis the settings can be changed by adjusting the pressure regulator and flow controller situated on the side panel. Please contact your authorized service provider or the factory for further instructions.

System Drain

Please ensure that the drain port at the rear of the compressor is led to a suitable connection or container, It should be noted that the generator will expel considerable amounts of water from this port. If a container is used it should be emptied at regular intervals.

Note: The container must not have an airtight seal.

Service Requirements

Service Schedule

Service Interval	Component	Part No.	Qty.
12 months	Coalescing filter element – Stage 1	00-0031	1
	Coalescing filter element – Stage 2	00-0032	1
	Inlet filter element	02-4640	1
	RAC filter element	00-4425	1
3750 hours	Compressor assembly	08-8141	1
Alternative to compressor assembly **	Compressor re-fit kit	06-5529	1

Table 3: Service schedule

** Compressors can be re-fitted as an alternative to replacement up to a maximum of 3 times, this is a more cost effective solution, however a degree of technical expertise is required and can be time consuming. Please contact your service provider for more information.

Service Indication

The N418LA counts the accumulative run-time (in hours) for the internal compressor. The Generator has the following Service Indication Stages:-

Stage 1

Once the compressor reaches a total of 3750 hours, the service LED will illuminate.

The service system can only be reset after intervention of a trained and authorized technician.



It is highly recommended that the compressors are serviced or replaced after 3750 run hours to prevent any unplanned downtime. Please contact your service provider for more information

Stage 2

If the compressor reaches a total of 4000 hours, the service LED will begin to flash.



Once 4000 hours is reached it is highly likely that the compressors will fail in the near future. Please contact your service provider as soon as possible to arrange a service or replacement of your compressors.

Service Indication Reset

Once the service has been completed the Service Indication LED can be reset. This will be performed by the Peak Service Engineer or trained service representative that completes the service operation.

Service Plans

Peak Scientific offer two service plans. The Complete Service Plan, specifically designed for Generators operated in critical environments, also includes full breakdown cover, guaranteed response times and Generator upgrades if available. Our Standard Service Plan, covering the basic needs of our Generators, features special deals on spare parts and breakdowns.

If you want to know more about our Service Plan options and how we ensure that your instrument can run with the maximum uptime and performance, please contact us at maintenance@peakscientific.com

Cleaning

Clean the outside of the Generator only using warm soapy water and a clean damp cloth. Ensure the cloth is thoroughly rung out to remove excess fluid prior to use.



Cleaning should only be undertaken with the power switched off and the power cord removed from the rear of the Generator.



Under no circumstances should any solvents or abrasive cleaning solutions be used as these can contain fumes that could be harmful to the Generator.

High Duty Indication

This indicator monitors the running condition of the internal compressor and illuminates when it has been operating continually for a period of 8 hours.



There are a number of extreme conditions that can affect the duty cycling of the compressor. These extremes include very high ambient temperatures, low supply voltages, a very high flow requirement and locations of high altitude. Any one of these or a combination of a number of these extremes can be evident in a customer site.

While the Generator is designed to operate fully in these conditions it should be noted that the effect of these extremes can force the compressors to run continually. The compressor is fully capable of running continually with no detrimental effect. However it should be noted that if this is the case it will increase the duty and it will reach the 3750 hour recommended service interval quicker.

High Duty Indication Reset

If the compressor has been operating continually for a period of 8 hours the indicator light will be illuminated. Once the compressor returns to a cycling mode, the indicator light will automatically switch off. There is no manual intervention required.

Trouble Shooting

Problem	Possible Solution
The Generator will not switch on and the power switch does not illuminate.	<ul style="list-style-type: none"> • Ensure power cord is plugged into the Generator and that the power socket is turned on. • Check the fuse in the power cord plug. • Contact your service provider. 
The Generator will not switch on but the power switch is illuminated.	<ul style="list-style-type: none"> • Disconnect power cord from the rear of the Generator. Open the right hand panel and check the fuse. Reconnect power cord. • Contact your service provider. 
Compressor is running but pressure is not building.	<ul style="list-style-type: none"> • Contact your service provider.
The mass spec is reporting low pressure.	<ul style="list-style-type: none"> • Check pressure gauges are showing normal pressure. • Contact your service provider.
Yellow "SERVICE" LED on front panel is on constantly.	<ul style="list-style-type: none"> • A compressor(s) due for service. Contact your service provider. • Refer to Service Indication section of this manual for further information.
Yellow "SERVICE" LED on front panel is flashing.	<ul style="list-style-type: none"> • A compressor(s) is overdue for service. Contact your service provider urgently. • Refer to Service Indication section of this manual for further information.

Peak Scientific UK

Fountain Crescent
Inchinnan Business Park
Inchinnan
PA4 9RE
Scotland, UK

Tel: +44 (0)141 812 8100
Fax: +44 (0)141 812 8200

Peak Scientific Germany

Herriotstrasse 1
60528 Frankfurt

Germany

Tel: +49 (0)69 677 33 490
Fax: +49 (0)69 677 33 200

Peak Scientific Taiwan

4F.-6, No.736
Zhongzheng Rd.
Zhonghe Dist.
New Taipei City

Tel: +886 2 8226 2383
Fax: +886 2 8226 9499

Peak Scientific North America

19 Sterling Road
Suite #1
Billerica, MA 01862

USA

Tel: +1 866 647 1649
Fax: +1 978 608 9503

Peak Scientific China

Room 606 Building 1
Lane 2277 Zuchongzhi Road
Pudong New Area
Shanghai
201203, China

Tel: +86 21 5079 1190
Fax: +86 21 5079 1191

Peak Scientific Brazil

Peak Scientific Brasil
Av. Quieroz Filho
1700 – torre Sunny-Conj. 602
São Paulo SP Brasil

Tel: +1 866 647 1649

Peak Scientific India

202, Amsri Shamira
Old Lancer Line
Opp. St. Mary's Degree College
S.D. Road Secunderabad
500 025, India

Tel: +91 40 2780 0663
Fax: +91 40 2780 0663

Peak Scientific Mexico

Solon 352
Col. Los Morales Polanco
11530 Mexico, D.F.

Mexico

Tel: +1 866 647 1649
Fax: +1 978 608 9503

Peak Scientific Japan K.K.

2-7-56, 2F Fuji Building 28
Kita Aoyama, Minato-Ku
Tokyo, Japan
107-0061

Tel: +81 3-6864-0468

Peak Scientific Africa

PO Box 478
Somerset Mall
7137

South Africa

Tel: +27 (0)2185 16542
Fax: +27 (0)8654 64473

Peak Scientific Australia

PO Box 65
Belmont
Victoria 3216

Australia

Tel: +61 1300 965 352

Peak Scientific Singapore

3 Science Park Drive
#03-14 The Franklin
Science Park Drive 1
Singapore, 118223

Tel: +65-6777 1966
Fax: +65-6777 1978