

General Information for Agilent Smart SPME Arrows



This user guide contains important notes for the operator. It is highly recommended for operators to become familiarized with the product before use.

- PAL3 Firmware 3.1 or higher is required for the use of Smart SPME Arrows with the complete scope of functions.
- The use of the SPME Arrow Conditioning Module and the Heatex Stirrer together with Smart SPME Arrows is essential. The SPME Fiber Conditioning Module cannot be used with Smart SPME Arrows.
- Due to the larger outer diameter (od) of SPME Arrows, the inlet turn top assembly of the gas chromatograph (GC) will require a modification. Please contact your GC provider for more information.
- Smart SPME Arrows ods are visually identifiable by a red (1.1 mm od) or yellow (1.5 mm od) holder.

Table 1. Smart SPME Arrow ordering information. All Smart SPME Arrows have a phase length of 20 mm.

No.	Outer Diameter	Phase Thickness	Color Code	Set of 3 Smart SPME Arrow Description	Part Number
PDMS Smart SPME Arrow					
1	1.1 mm	100 μm	Red		5610-5862
2*	1.5 mm	100 μm	Red		5610-5866
Acrylate Smart SPME Arrow					
3	1.1 mm	100 μm	Gray		5610-5858
Carbon WR/PDMS Smart SPME Arrow					
4	1.1 mm	120 μm	Light blue		5610-5859
5*	1.5 mm	120 μm	Light blue		5610-5863
DVB/PDMS Smart SPME Arrow					
6	1.1 mm	120 μm	Violet		5610-5860
7*	1.5 mm	120 μm	Violet		5610-5865
DVB/Carbon WR/PDMS Smart SPME Arrow					
8	1.1 mm	120 μm	Dark gray		5610-5861
9*	1.5 mm	120 μm	Dark gray		5610-5864
PDMS Smart SPME Arrow					
10	1.5 mm	250 μm	Black		5610-5867
Smart SPME Arrow Selection for Method Development					
Smart SPME Arrow selection of five Smart SPME Arrow standard types No. 1, 3, 4, 6, and 10					5610-5868
Smart SPME Arrow selection of five Smart SPME Arrow standard types No. 1, 3, 4, 6, and 8					5610-5869

* Smart SPME Arrow wide types, for use with solvents or reagents, that may lead to moderate swelling of PDMS phases.

PDMS = Polydimethylsiloxane; Acrylate = Polyacrylate; Carbon WR = Carbon Wide Range; DVB = Divinylbenzene

Using Agilent Smart SPME Arrows

- Set the PAL gas input pressure to 2 bar when using Conditioning Module(s). This enables a conditioning gas flow above 15 mL/min to be reached.
- Do not extend conditioning times longer than necessary.
- The lifetime of SPME Arrow phase will decrease if exposed to maximum temperature for longer periods. Depending on your application, choose the lowest necessary temperature, not the highest possible.
- Operating temperatures include conditioning and desorption temperatures in the injector.
- Conditioning times can be applied for pre- and postconditioning.
- For liquid immersion techniques, a liquid wash step may help to reduce carryover.
- Prevent permanent storage at conditioning temperatures.
- For Agilent GCs, injector penetration depth is defaulted to 40 mm. Note that the optimal penetration depth may vary depending on other injector types.
- Early leakage of septa may occur if injector nuts are not tight enough or overtightened.
- SPME Arrows are specified for use at a maximum injector pressure of 50 psi.

Table 2. Operational parameters.

No.	Phase Thickness	Maximum Temperature (°C)	Recommended Operating Temperature (°C)	Conditioning Time (min) Min Max Recom.	Arrow Rinsing Solvent	Arrow Rinsing Time (min) Min Max Recom.
PDMS Smart SPME Arrow						
1, 2	100 μm	300	200 to 280	1 30 5	MeOH EtOH IPA	0.5 10 2
Polyacrylate Smart SPME Arrow						
3	100 μm	280	200 to 250	1 30 5	MeOH EtOH aliphatic HC	0.5 10 2
Carbon WR / PDMS Smart SPME Arrow						
4, 5	120 μm	300	200 to 300	1 30 5	MeOH	0.5 10 2
DVB / PDMS Smart SPME Arrow						
6, 7	120 μm	300	220 to 270	1 30 10	MeOH EtOH IPA	0.5 10 2
DVB / Carbon WR / PDMS Smart SPME Arrow						
8, 9	120 μm	300	220 to 270	1 30 10	MeOH EtOH IPA	0.5 10 2
PDMS Smart SPME Arrow						
10	250 μm	300	220 to 280	1 30 10	MeOH EtOH IPA	0.5 10 2

MeOH = Methanol; EtOH = Ethanol; IPA = Isopropanol (2-propanol); aliphatic HC = aliphatic hydrocarbons (e.g. n-Hexane)

Please refer to Table 3 for additional consumables for use with SPME Arrows.

Table 3. Additional part numbers for use with Agilent Smart SPME Arrows.

Additional Consumables	
5190-6168	Inlet liner, ultra inert, splitless, straight, 2 mm id
5183-4757-100	Inlet septa, bleed and temperature optimized (BTO), nonstick, 11 mm
5183-4759-100	Inlet septa, Advanced Green, nonstick, 11 mm
5182-3446	Merlin microseal nut for use with SPME Arrows
5182-3447	Replacement microseals for use with 1.1 mm SPME Arrows
5182-3448	Replacement microseals for use with 1.5 mm SPME Arrows
5188-6537	Vial, screw top, headspace, amber, round bottom, 20 mL, 23 × 75 mm, 100/pk
5188-2753	Vial, screw top, headspace, clear, 20 mL, 23 × 75 mm, 100/pk
5188-2759	Caps/septa, screw, headspace, steel, high temperature septa, certified, 18 mm, 100/pk

Agilent Smart SPME Arrow conditioning, cleaning, and handling

Caution: Without gas protection, the Smart SPME Arrow surface will be damaged if exposed to elevated temperatures.

Smart SPME Arrow preconditioning

Before analytical use, it is mandatory to precondition each Smart SPME Arrow at a specified temperature in an inert gas phase environment.

Generally, it is recommended to precondition the Smart SPME Arrow 20 °C above the planned operating temperature, while respecting the maximum temperature threshold. The lifespan of the Smart SPME Arrow can be extended if it is not unnecessarily preconditioned at maximum temperature. Recommended temperatures and conditioning times are provided in Table 2.

Running a preconditioning step is highly recommended if the Smart SPME Arrow has either been stored without protection, been unused for a prolonged period, or if obvious dust particles are visible.

Smart SPME Arrow conditioning

It is highly recommended to condition the Smart SPME Arrow after thermal desorption of the analytes has been completed. This conditioning is a preparatory step for the next analytical run. This helps to eliminate all possible contaminants from the Smart SPME Arrow that have not been desorbed and transferred to the GC column.

To avoid contamination of the GC inlet system and/or the GC column, it is recommended to remove the Smart SPME Arrow after the thermal desorption step from the GC injector and move the Smart SPME Arrow Tool to the SPME Conditioning Module for the conditioning step.

The larger sorption phase surface area of the Smart SPME Arrow can trap impurities from the ambient atmosphere if a Smart SPME Arrow has been left in the open. Agilent recommends running a blank before running a series of analytical samples. Evaluating the baseline level of the GC detector helps to ensure that the entire system, such as the Smart SPME Arrow, the GC inlet, the GC column, and detector, is free from any contaminants.

Smart SPME Arrows rinsing

It is possible to clean the Smart SPME Arrow using an organic solvent. The recommended types of solvents are listed in Table 2. Only use the referenced solvents. Other solvents can cause a swelling of the PDMS phase, which would lead to significant damage.

It is important that a Smart SPME Arrow is not cleaned mechanically by any means; do not touch the Smart SPME Arrow with fingers, not even when wearing gloves. The cleaning process can be done manually by dipping the Smart

SPME Arrow into a container filled with the appropriate solvent or in an automated manner by defining a vial for cleaning.

To avoid potential solvent mix-ups, do not use the wash or waste solvents from the PAL System wash module.

General remarks for Smart SPME Arrow conditioning

Table 2 summarizes the various parameters for conditioning and cleaning. The values provided are empirical values that are suitable for a number of applications and give reliable results.

It is not possible to visually judge the Smart SPME Arrow quality if there are no obvious signs of major mechanical damage, such as a fracture.

Any sign of staining, caused by a starting vitrification of the surface in case of a PDMS Smart SPME Arrow, or signs of a yellowish discoloration in the case of a Polyacrylate Smart SPME Arrow, does not give any indication of the remaining lifespan of the particular Smart SPME Arrow.

To extend the lifetime of a Smart SPME Arrow, exposure to high temperatures should be minimized. Do not exceed the maximum temperature for each Smart SPME Arrow type, as shown in Table 2.

Headspace extraction: sample volume and penetration depth

For headspace extractions using Agilent 20 mL vials:

Sample Volume (mL)	Penetration Depth (mm)
<10	30
>10	Not recommended

Liquid immersion: sample volume and penetration depth

For liquid immersion methods, we recommend you use Agilent 20 mL headspace vials with the following liquid sample volumes and their respective penetration depths. These settings will give best extraction conditions with minimized moisture transfer for liquid immersion.

Sample Volume (mL)	Penetration Depth (mm)
<15	Not recommended
15	50
16	45
17	40
18	30
>18	Not recommended

Typical lifetimes

The lifetime of Smart SPME Arrows is dependent on method conditions. In general, the lifetime is decreased by thermal stress during conditioning and desorption. Generally, headspace applications use lower temperatures which can extend Smart SPME Arrow lifetime compared to direct immersion techniques.

The lifetime of SPME Arrows is also dependent on sufficient gas flow during desorption and conditioning (i.e. 20 mL/min). For liquid immersion, any particles in the liquid phase should be avoided. In case of particle-loaded liquids, filtration or centrifugation before extraction can increase the lifetime.

Mandatory tool and modules for the use of Smart SPME Arrows

Agilent Smart SPME Arrows are compatible with the following tool and modules:

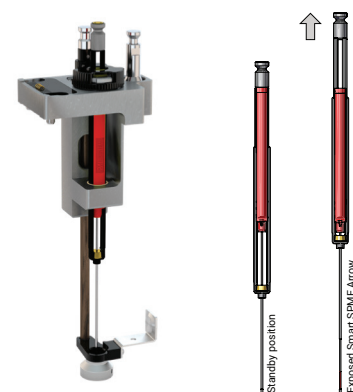

SPME Arrow Tool

Agilent Smart SPME Arrows are fully functional with the PAL3 Series II system. The SPME Arrow Tool is compatible with both traditional SPME Arrows and Smart SPME Arrows. Smart SPME Arrows do not require the use of a separate Arrow holder. For the PAL3 System, the Smart SPME Arrows allow a maximum needle penetration depth of 70 mm.

Note: This tool cannot be used with SPME Fibers, and is not compatible with previous PAL and PAL-xt Systems.

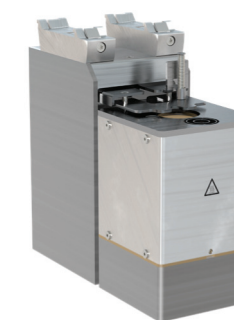

Heatex Stirrer

A Heatex Stirrer is mandatory to incubate, equilibrate, and extract samples either from headspace or liquid phase (direct immersion).



SPME Arrow Conditioning Module

The SPME Arrow Conditioning Module offers the functionality to clean (bake-out) the inserted Smart SPME Arrow in an inert gas phase after the analytical process to prepare it for the next analysis. This module is strongly recommended since it will help to protect the GC injection port from contamination and free up the port after thermal desorption.

www.agilent.com/chem

DE44271.7621527778

This information is subject to change without notice.

© Agilent Technologies, Inc. 2021
Printed in the USA, March 26, 2021
5994-3137EN